

ThermalTronix

TT-13T-HTI

Thermal Image Camera

User Manual

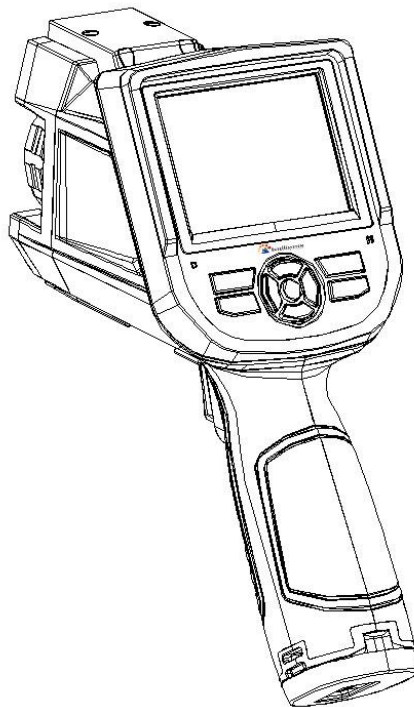

! Warnings, Cautions and Notes

Definitions

- ! **WARNING** Could cause bodily injury or death.
- ! **CAUTION** Could cause damage to equipment or permanent loss of data.
- ! **NOTE** provides useful information to the operator.

Important Information – Read before using the Instrument

- ! **WARNING** – Laser Radiation is emitted from this device. **Do Not** stare into Laser Beam.
Class 2 Laser, 635 nm, 0.9mW
- ! **CAUTION** - Never point the lens directly toward a strong radiation source (ie. Sun, direct or reflected laser beam, etc), with power on or power off, as damage may result to the thermal detector used inside. **Permanent damage may result!**
- ! **CAUTION** - The original shipping carton should be kept for use for future transportation. Do not drop, shake or impact the thermal imager excessively, in use or during transportation.
- ! **CAUTION** - Store the unit in its original case in a cool, dry, well-ventilated area away from strong electromagnetic fields.
- ! **CAUTION** - Protect the surface of the lens from being stained or damaged by foreign objects such as sludge or chemicals. Please replaces the lens cap after use.
- ! **CAUTION** - Please remember to backup image data regularly to avoid losing important data.
- ! **NOTE** - For maximum measurement accuracy, allow 3 to 5 minutes for camera to stabilize after initial power up.
- ! **NOTE** - Each camera is factory calibrated. It is recommended that calibration be performed every 12 months.

! **CAUTION** - Do not open case. Unit does not contain any user serviceable parts. Repair should be performed by factory authorized technicians only.

Contents

! Warnings, Cautions and Notes.....	1
1 Introduction	4
1.1 Standard accessories.....	6
1.2 Optional accessories	6
2 Camera overview.....	7
2.1 Function keys.....	7
2.2 Interface	11
3 Basic operation.....	12
3.1 Battery Installation and Replacement.....	12
3.1.1 Inserting or removing battery	12
3.1.2 Replacing battery	14
3.2 Battery safety and usage	14
3.3 Quick access	15
3.3.1 Capture an image	15
3.3.2 Temperature measurement.....	16
3.3.3 Freeze and save image.....	17
3.3.4 Viewing stored Images.....	18
3.3.5 Export saved images.....	18
4 Operation guide.....	19
4.1 Graphic interface description.....	19
4.1.1 Screen graphic interface.....	19
4.1.2 Main menu	20
4.1.3 Dialog box.....	20
4.1.4 Prompt box interface.....	21
4.2 Measurement.....	21
4.3 Auto/Manually	23
4.4 Setup menu.....	23
4.4.1 Measuring Setup	24
4.4.2 Adjustment setup.....	25
4.4.3 Analysis setup.....	26

4.4.4	Date/Time setup.....	27
4.4.5	System setup	28
4.4.6	System Info	29
4.4.7	Factory Default	30
4.5	File.....	31
4.5.1	Open.....	31
4.5.2	Save.....	32
4.5.3	Auto Save.....	34
4.5.4	Delete.....	35
4.5.5	Format.....	36
5	Technical specifications	37
	The information contained in this document is subject to change without notice.....	38
	Troubleshooting.....	39
	Appendix A	40
	Common material emissivity (FYI)	40
	Appendix B	41
	Factory default parameter setting table	41

1 Introduction

Thank you for choosing Intellisystem Instruments "TT-13T-HTI" hand-held infrared thermal imager.

Model Identification

TT-13T-HTI imagers use the detector with 25um 160*120, and measurement range from -20°C~+350°C

Features

TT-13T-HTI include the following features:

User selectable Auto or manual level and span control

°C, °F or K measurement scale

6 user selectable color palettes

11 user selectable languages

Hot temperature spot measurement

Cold temperature spot measurement

1 removable spot measurements

High temperature Alarm setting

T Reflect - Reflected temperature compensation

Freeze screen for viewing current image

Video Output – NTSC or PAL

1 Areas measurements

Image storage via TF card

T Correct – Measurement Offset correction

Built in Emissivity Table list of common materials

Applications:

Preventive maintenance

- Power industry: Power line and power facility thermal state checking; problem and defect diagnosis.

- Electrical system: Identify potential circuit overloads.
- Mechanical system: Reduce downtime and avoid catastrophic failure.

Construction science

- Roof: Quick identification of water penetration problems.
- Structure: Commercial and residential energy audits.
- Moisture detection: Determine root cause of moisture and mildew.
- Evaluation: Evaluate the resolution to ensure the area completely dry.

Others

- Iron and steel industry: Inspect steel refining and rolling processes; diagnose hot-blast stove defects; detect the embryo temperature of armor plate, etc.

- Firefighting: Forest fire prevention and detection of latent ignition source. Preventive detection on specific materials of auto-ignition. Detection of potential spark ignition sources.

- Medical: Human body surface temperature detection and screening.

- Petro/chemical: Oil pipeline status inspection; material surface temperature detection; insulation inspection; power equipment status, etc.

1.1 Standard accessories

- Infrared thermal image camera (with wrist strap)
- Carrying case
- Lithium ion batteries (2)
- User manual, Infrared report and analysis software system CD
- Lithium battery charger
- Lens cap
- TF card
- TF card reader

1.2 Optional accessories

- Screen cover for using under sun light outdoor.
- Power adapter (with power cable and plug)
- USB Cable
- Video Out cable
- Rubber Cover for screen
- Power adaptor

2 Camera overview

2.1 Function keys

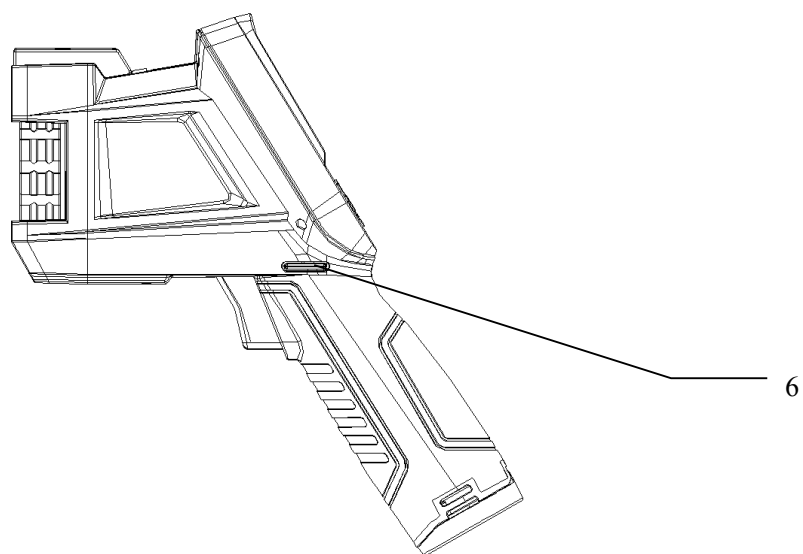
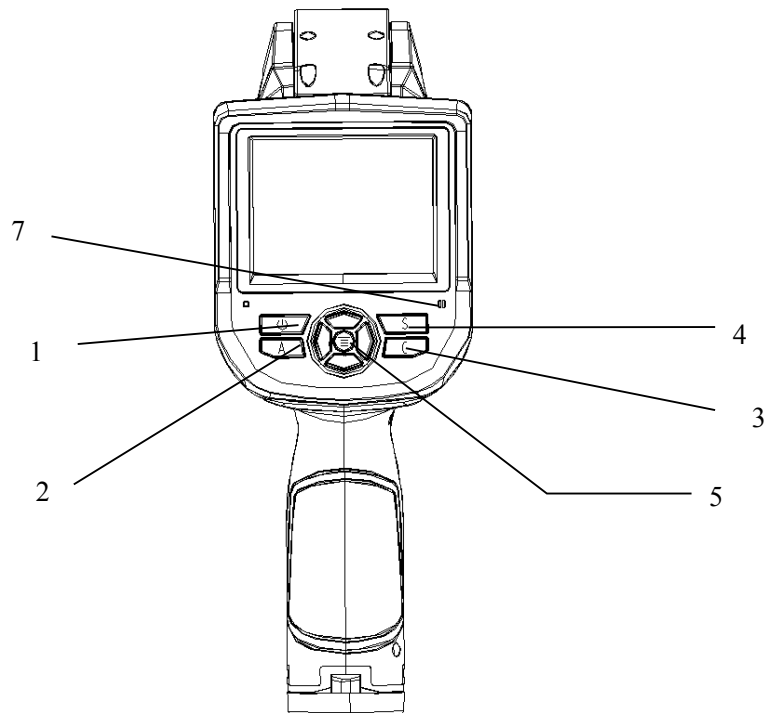

[1] Power key

Press and hold the Power Key for > 3 seconds to power on/off the camera.

! Note: After powering off, please wait ten seconds before powering the camera on again.

[2] Select/Auto key (Marked "A")

The "A" or attribute button performs 2 functions.

a) The first function is modification of selected parameters. It is obtained by a quick press and release (less than 2 seconds), with this functions to modify their parameters. Subsequent presses will "scroll" through the available parameters. The selected function will be highlighted in yellow. The functions include:

- **Measurement points, areas, and lines**

Cursors and lines - pressing the arrow keys will move their position. Pressing the Menu key will pop up the attribute box. Pressing the **C** key will delete the selected parameter.

Areas - Arrow keys adjust the attribute specified in the pop up attribute box. Pressing the Menu key will pop up the attribute box. In this box, the user can select to adjust either position or size of the area. After selection, the arrows will then adjust the attribute.

- **Color Palette**

Pressing the left or right arrows will scroll through the available color palettes, displaying their name above the palette. The selected palette will become active after about 3 seconds of selecting it and will be set as the default power on palette.

- **Level/Span values**

Pressing the left or right arrow will reduce or increase the Span and pressing the up or down arrow will reduce or increase the Level. If the unit is in Automatic mode, modifying any of these parameters will select Manual mode.

b) The second function performed is to force an internal calibration cycle. This is performed by pressing and holding the **A** key for 5 seconds or more. The camera will make automatic correction to get the most accurate thermal measurement.

[3] Cancel/Camera key (Marked "C")

- Pressing and releasing the **C** key cancels the present operation when in **Menu** mode.
- Pressing and releasing the **C** key when an image is frozen or being viewed from memory, will return to real-time measurement status.
- When a parameter is selected, such as a measurement cursor, pressing the **C** key will delete the highlighted measurement.

[4] Freeze/Save key (Marked "S")

Used for freezing or saving thermal image. Press the key once to freeze the image. Press Confirm to save the image or Press C to return to real-time measurement. If Voice recording is enabled, Voice comment dialog box will display.

[5] Menu/Confirm key (bar)

Includes **Up**, **Down**, **Left**, **Right** and **Menu/Confirm** (center) keys. Function varies with operation mode.

In **Menu mode**, it is used for menu selection. **Up** and **Down** keys are for same level of menu operation. **Left** and **Right** keys are for different levels menu operation. **Confirm** key (center) is to activate the menu and confirm the choice.

In **Image mode**, press **Up** or **Down** key to activate X2 digital zoom. The screen will display "X2" in the upper left corner. Press **Up** or **Down** key to return to the original image.

In **Spot Measurement** editing mode (activated immediately after adding a spot or by selecting via the **A** key), press the **Menu** key to pop up the attribute

box. Press four navigation keys to move the spot location.

In line temperature measurement editing mode (activated immediately after adding a line or by selecting via the **A** key), press the **Menu** key to pop up the attribute box. If measurement line is horizontal, press **Up** and **Down** keys to move the line location; press **Left** and **Right** keys to move the reference line. If measurement line is vertical, press **Left** and **Right** keys to move the line; press **Up** and **Down** keys to move the reference line.

In area measurement editing mode (activated immediately after adding an area or by selecting via the **A** key), press the **Confirm** key to pop up the attribute box. Select in the attribute box the parameter to be edited, either size or position. Press the four navigation keys to move the area location or change the size of the area.

[6] Trigger/Shortcut key

The trigger key serves as a shortcut to access the following functions:

Laser – Pulling trigger activates laser sight and releasing deactivates it.

Spot– Pulling and releasing trigger adds a spot. Pulling and releasing trigger again removes the spot.

Area –Pulling and releasing trigger adds an area. Pulling and releasing trigger again removes the area.

Save – the same with “S” key, pressing to initiate a Save cycle.

2.2 Interface

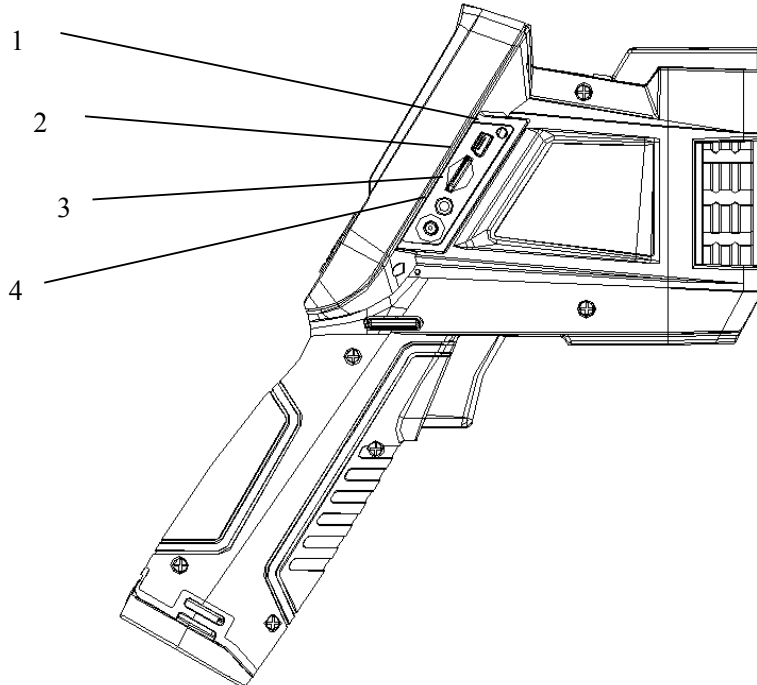

[1] USB output

Inserting USB cable to this port and connecting to computer for data transmission (only support USB2.0).

[2] TF Card slot

Accepting standard size TF card such as supplied 2GB capacity card, for device upgrade or image storage.

[3] Video port

It is a video output interface.

[4] Power interface

External power input interface. Power source should be +12VDC. Center pin is positive terminal.

3 Basic operation

3.1 Battery Installation and Replacement

3.1.1 Inserting or removing battery

Battery compartment is located inside the handle. Turn the cover counter-clockwise to remove. Remove battery for replacement.

12

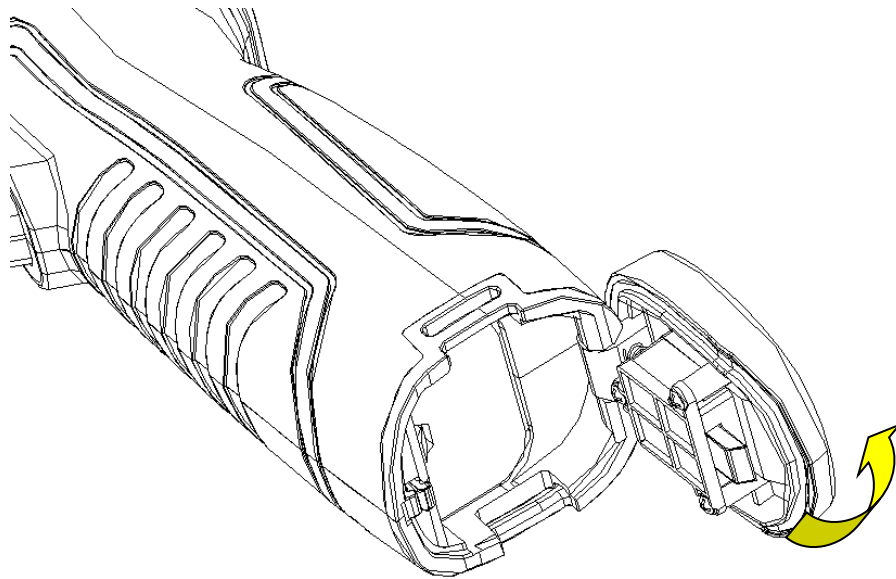

Insert the battery (the battery contacts must face into the battery compartment).

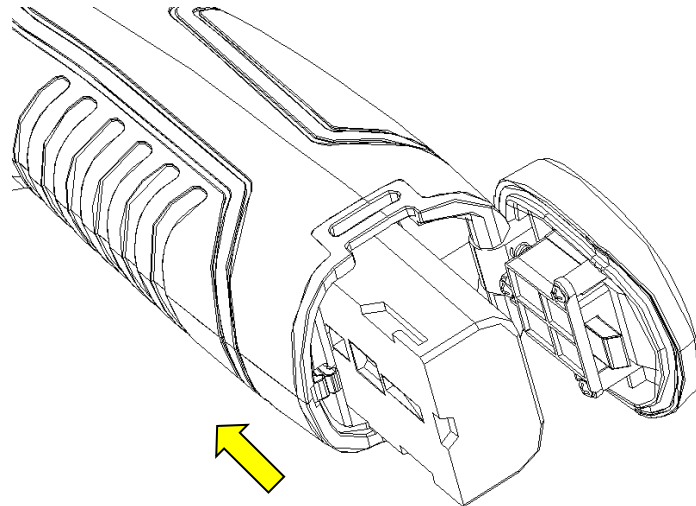

Replace the cover and screw down.

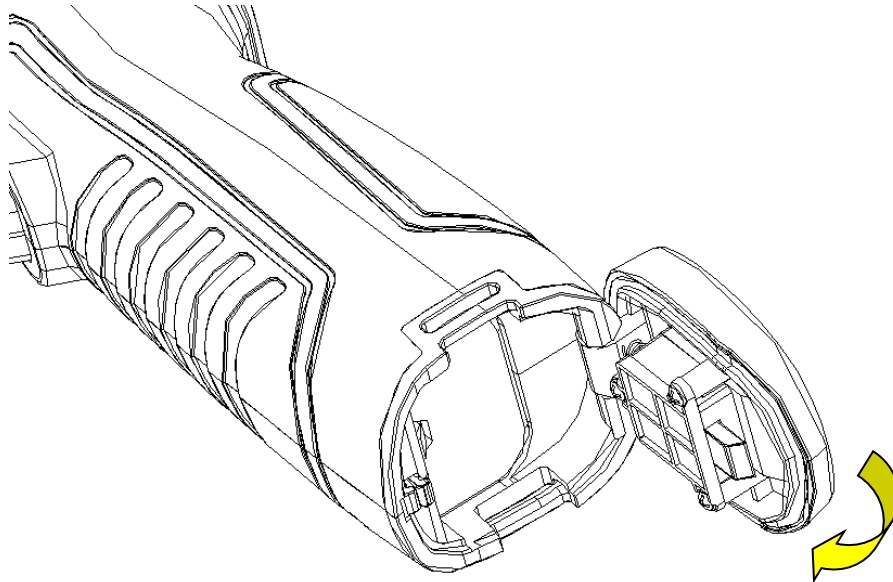

! CAUTION: Use only original manufacturer replacement battery. Use of incorrect battery may result in physical or electrical damage to the instrument due to incorrect voltage or physical size difference.

3.1.2 Replacing battery



14

When battery has approximately 5% charge remaining, the warning will be displayed and the instrument will turn off in approximately 3 seconds.



Powering off display

It's better to replace batteries now.

3.2 Battery safety and usage

- Batteries should be stored in an ambient temperature of -4°F (-20°C) to 67.9°F ($+20^{\circ}\text{C}$). Lithium batteries will self-discharge during storage, so they should be fully charged before storage. Self-discharge may affect long

term battery performance. Furthermore, it is recommended that the battery should be charged in a set time, as below;

Ambient temperature of:

- -4°F (-20°C) to 67.9°F (+20°C), once every 6 months
- 67.9°F (+20°C) to 113°F (+45°C), once every 3 months
- 113°F (+45°C) to 149°F (+60°C), once every month

- Battery should have greater than 50% charge prior to recharge.
- The ambient temperature for charging should be 32°F (0°C) to 104°F (+40°C). If under 32°F (0°C), the battery capacity will be diminished; if over 104°F (+40°C), the battery may overheat, resulting in permanent damage.

! WARNING:

- ! Never disassemble, incinerate or puncture battery
- ! Never short circuit the battery
- ! Keep battery dry
- ! Keep out of reach of children
- ! Always dispose of battery in accordance with local, state and federal regulations

3.3 Quick access

3.3.1 Capture an image

- After installing the battery, press and hold the power key (≥ 3 seconds) until the display comes on. After approximately 50 seconds, the power on routine will finish and the camera will start its measurements.
- Remove the lens cap and aim at the target. Adjust the focus for the clearest target thermal image.

! NOTE: Failure to properly focus the camera will result in increased measurement error.

3.3.2 Temperature measurement

- If no measurement cursors are on screen, add a measurement spot, area or line by pressing **MENU** and selecting Measurement. Press **CONFIRM** and scroll left or right to select the proper measurement parameter. Aim the cursor indicator onto the target object on the screen. The temperature will be displayed in the upper right corner of the screen. For highest accuracy measurements, force a calibration cycle by pressing the **A** key for 5 seconds until “**Calibrating**” appears in upper left portion of display.
- If you want to measure the current thermal image in detail, press S key to freeze the image for on-screen analysis. Save the image if future analysis is desired. For details, see Section 4.
- If the target object’s temperature is lower or higher than the limits of the camera, it will display <XXX° or >XXX° with XXX being the min or max temperature of the selected range.
- To modify the measurements attributes, select the measurement parameter, and then press the **Confirm** key. The screen will display the settings dialog box. The below figures are spot, line and area measurement respectively.

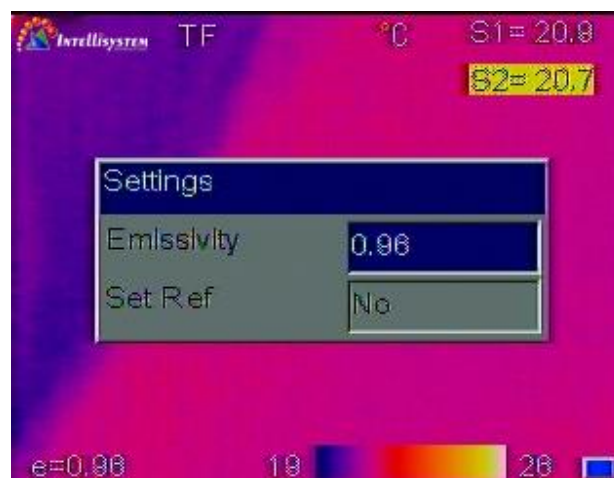

Spot settings include emissivity and reference temperature. When **Set Ref**

is set as **Yes**, the displayed values of other measurements will be their delta from this measurement.

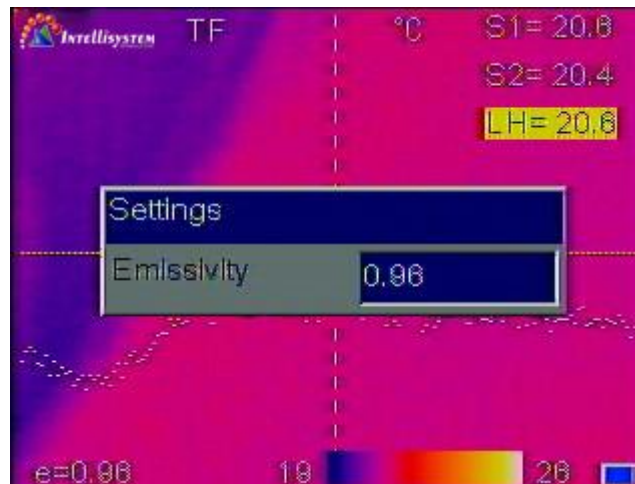

17

Line settings only include the emissivity.



Area settings can modify the emissivity, area measurement type and area move parameter. Measurement types are Min Temp, Max Temp or Average Temp. Area Move parameter choices are Position or Size. The selected parameter will be adjusted by the directional arrow keys. When "Set Ref" is set as **Yes**, the displayed values of other measurements will be their delta from this measurement.

3.3.3 Freeze and save image

Press **S** key to freeze the image and select "**C**" to exit the operation.

There are three ways to save the image:

Intellisystem Technologies S.r.l.

Via Augusto Murri, 1 - 96100 Siracusa - Phone +39 (0)931-1756256 / +39 (0)2-87167549 - Mobile (+39) 335 1880035
em@il: info@intellisystem.it WEB: http://www.intellisystem.it

- Press **S** key to freeze the image and then select "**Save**" to save the image, or select "**Cancel**" to exit the operation.
- Press **Menu** key to activate the main menu. Choose **File->Save** and the system will initiate the save cycle.
- With the "Trigger" parameter, located in Setup->Sys. Setup->Trigger, set to "Save Key", pulling and releasing the trigger key will initiate the save cycle.

3.3.4 Viewing stored Images

- Press **Menu** key to activate the main menu. Choose **File->Open** to open the image.
- When image is opened, choose **Left** or **Right** keys to select the previous or next images respectively.
- If the instrument is in IR mode, it will display all IR images of each saved image, it will display "**No Image**" if there is no IR image for that saved image.
- Press **C** key to exit the Image view mode and return to the real-time measurement mode.

3.3.5 Export saved images

- Use of USB port to download images in TF card. With a standard USB cable, connect device port to PC and export saved images.
- Remove the TF card and insert into TF card reader, connect to USB port on PC and export saved images.

4 Operation guide

4.1 Graphic interface description

4.1.1 Screen graphic interface

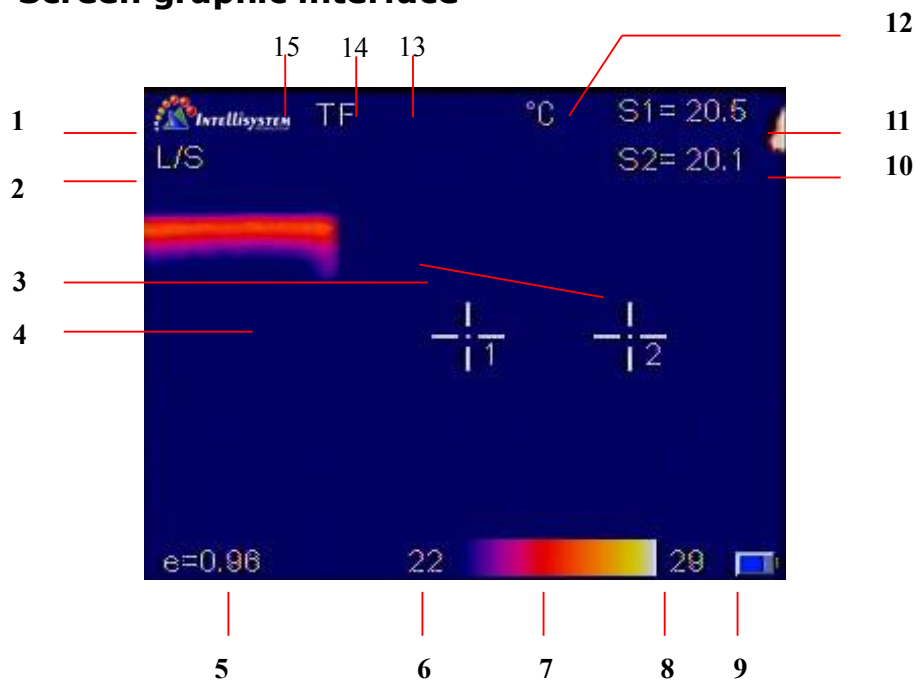

[1] **Company logo:** Intellisystem

[2] **Operating status:** displays the current operational status.

[3] **Spot temperature measurement:** White crosshair.

[4] **Selected spot temperature:** Yellow crosshair, and show by “*” .

[5] **Emissivity:** Indicates Imagers emissivity setting.

[6] **Minimum temperature:** Indicates minimum value of the palette.

[7] **Palette:** Palette bar. User can choose different palettes.

[8] **Maximum temperature:** Indicates maximum value of the palette.

[9] **Battery status:** Indicates the current battery status.

[10]、 [11] **Result:** Indicates the temperature value of the target object. Black and yellow denotes the temperature value of the selected object.

[12] **Temperature unit:** Three options: °C, °F or K.

[13] **External lens symbol:** Displays "0.5x" for wide-angle or "2x" for telephoto lens.

[14] **SD card symbol:** Displays "SD" when TF card is installed.

4.1.2 Main menu

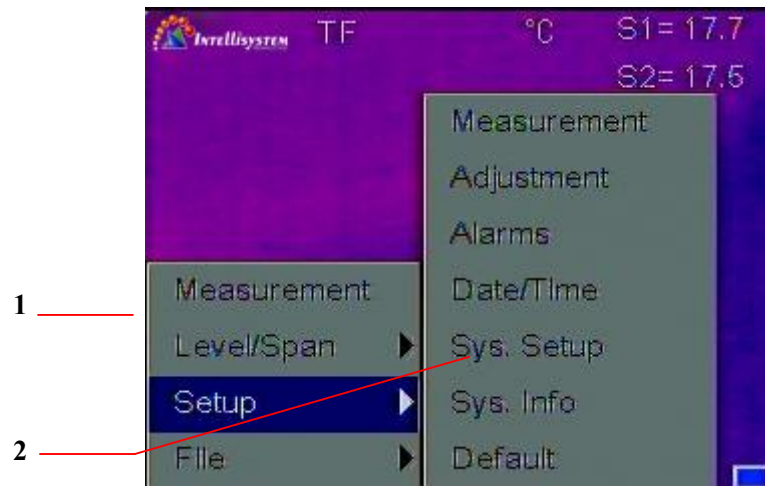

20

[1] **Main menu:** Displays four options: Measurement, auto/manually, Setup, and File.

[2] **Low-level menu:** The > indicates a low-level menu is available, accessed by the right arrow key.

4.1.3 Dialog box



[1] **Dialog box name:** Displays the dialog box name, e.g. Measuring Setup.

[2] **Item title:** A dialog box may contain several items, such as Temp Range.

[3] **Item content:** Items show specified content. Black means valid or changeable and white means invalid for this selection.

[4] **Unit:** Indicates the current selected temperature unit.

4.1.4 Prompt box interface



21

[1] **Prompt box name:** Display the prompt box name, e.g. Del file.

[2] **Content:** Display the content in the prompt box, e.g. Del Image File?

4.2 Measurement

Used for adding or deleting a measurement. Press **Menu** key to activate the main menu. Select **Measurement** and press **Confirm** key. It will display the Measurement dialog box. Use the **Left** and **Right** arrows to scroll through the available measurement options. Highlight the option you wish to use and press **Confirm** key. Options are:

- None – Deletes all measurements from the screen.
- Add Hot Spot – adds a moving cursor that automatically displays the

hottest spot in the image. Designated by SH and +H.

- Add Cold Spot – adds a moving cursor that automatically displays the coldest spot in the image. Designated by SL and +L.
- Add Spot – adds up to 2 fixed cursors, user adjustable by the cursor editing mode. Designated by S1, +1 and S2, +2.
- Horizontal – Adds horizontal line measurement to display profile of temperatures along the line. Designated by LH. Either Horizontal or Vertical can be enabled at one time, but not both.
- Vertical – Adds vertical line measurement to display profile of temperature along the vertical line. Designated by LV. Either Horizontal or Vertical can be enabled at one time, but not both.
- Area – adds up to 3 area boxes, with min, max or average detection within each box. Areas can be sized and moved by the user. Designated by []1, []2 and []3.

! NOTE: To delete a single object, press A key to select the object and then press C key to delete.

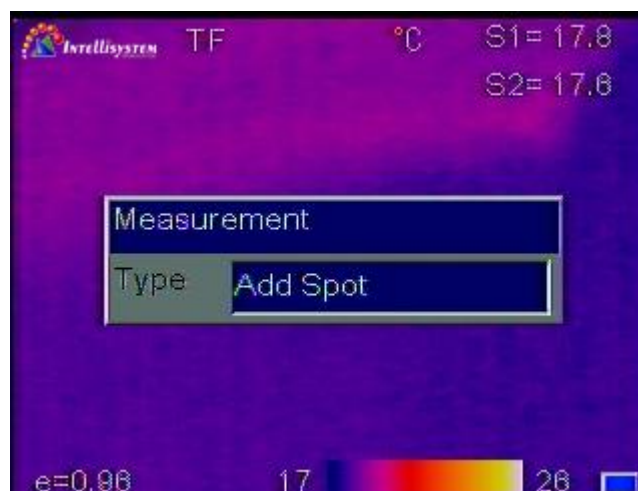

4.3 Auto/Manually

By adjusting the temperature and color corresponding relation, users can observe enhanced image quality and easily find and analyze thermal fault. There are two operational modes Auto/Manually available.

Press **Menu** key to activate the main menu and select **Auto/Manually**. The low-level menu will display the inactive mode followed by a "?". Pressing the **>** key followed by the **Confirm** key will switch to the displayed mode. Press **A** key to select palette or adjust it manually.

In **Auto** mode, the camera automatically determines the low and high temperature levels to assign to the lower and upper ends of the palette. In **Manually** mode, the Operator may assign the lower and upper end values to enhance the image quality by adjusting the temperature to color relationship. In **Manually** mode pressing the **left** or **right** arrow will reduce or increase the Span and pressing the **up** or **down** arrow will reduce or increase the Level.

4.4 Setup menu



4.4.1 Measuring Setup



Press **Menu** key to activate the main menu. Select Setup->Measure Set and press **Confirm** key to pop up the Measuring Setup dialog box. User can view or set temperature range, lens type, temperature unit, ambient temperature, reference type and reference temperature. Press **Up** and **Down** keys to choose different items, **Left** and **Right** keys to modify the item contents.

- **Temp Range:** Select Temp Range according to target temperature
 low Temp Range (-20°/180°C) or high Temp Range (100°/600°C)
 TT-13T-HTI (-20°/350°C)
- **Lens:** Select **Standard**, **Telephoto** or **Wide Angle**. A mark will display when **Telephoto** or **Wide Angle** is selected.
- **Temperature unit:** Select between °C, °F and K scales.
- **Ambient temperature :** Camera will display internal ambient temperature automatically. Used for automatic calibration and is not user editable.
- **Reference type:** When Ref Type is "On", the temperature of the measured object displayed by the cursor on the screen is the difference from the selected reference or the reference temperature set below.

- **Reference temperature:** When **Ref Temp** is enabled, this item is editable. A fixed temperature may be entered as the reference temperature, or select a measurement object in "**Ref Temp**".

4.4.2 Adjustment setup

25

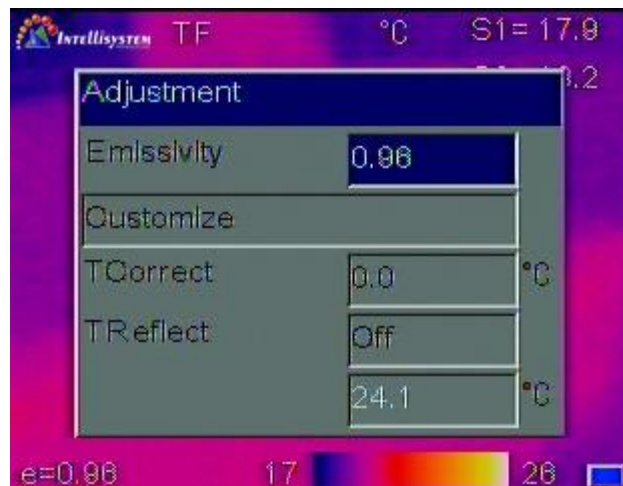

Press **Menu** key to activate the main menu. Select **Setup->Adjustment** and press **Confirm** key to pop up the Adjustment dialog box. User may set emissivity, temperature correct and ambient temperature. Press **Up** and **Down** keys to choose different items, **Left** and **Right** keys to modify the item contents.

- **Emissivity** : The emissivity of a given material will vary with temperature and surface finish. If not set manually, system will use the default value. Appendix A provides emissivities of common materials.
- **Customize:** Select material from pre-defined list via left and right keys.
- **Correct:** Temperature correction setup.
- **Ambient temperature:** when **Ambient Temp** is enabled, user can input the value of ambient temperature.

4.4.3 Analysis setup



Press **Menu** key to activate the main menu. Select **Setup->Analysis setup** and press **Confirm** key to pop up the Analysis dialog box. User can set temperature alarm, alarm temperature, alarm color, isotherm color, isotherm temperature and isotherm width. Press **Up** and **Down** keys to choose menu items, **Left** and **Right** keys to modify the item contents.

An alarm is triggered when a measurement cursor's measurement meets or exceeds the **Set Alarm Temp** setting. All pixels above this temperature will change to the color as set in **Alarm Color**. When the **Alarm Color** is set to **None**, only the audible alarm will sound. When using alarms with **Area** measurements, the selected measurement mode, **Min**, **Max** or **Average** will have to meet or exceed the set temperature in order to trigger the alarm.

- **Temp Alarm:** **Off** disables alarm function, **On** enables alarm function and allows setting of **Set Alarm Temp** and **Alarm Color**.
- **Alarming Temp:** Sets the alarm detection temperature. Only enabled when Temp Alarm is set to **On**.
- **Alarming Color:** Selects the color in which the alarming pixels are displayed. If set to None, no changes are made to the screen's color.

Only enabled when **Temp Alarm** is set to **On**.

- **Isotherm Color**: Activates the Isotherm display by displaying the image in the set temperature range by the specified color. Setting to **Off**, disables the feature.
- **Isotherm Temp**: Sets the center temperature of the isotherm.
- **Isotherm Width**: Sets the width of the displayed Isotherm band. For example, if **Isotherm Temp** is set to 122°F (50°C) and **Isotherm Width** is set to 1°C, the isotherm band will be from 121.5F (49.5°C) to 122.5°F (50.5°C).

4.4.4 Date/Time setup

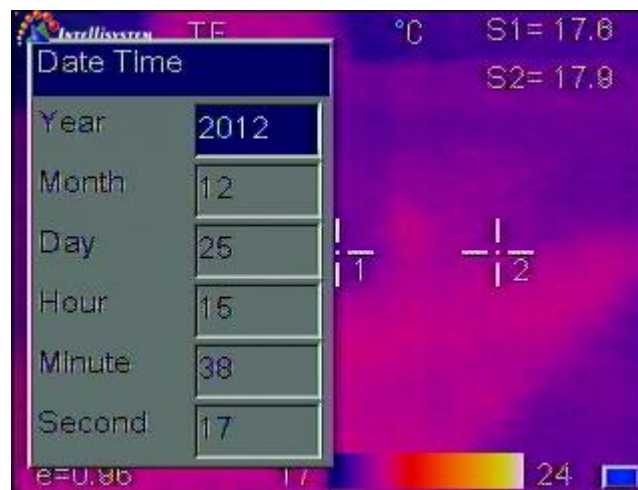

Allows the user to set the system date and time. After setting, the camera will save the current setting.

Press **Menu** key to activate the main menu. Select **Setup->Date/Time** and press **Confirm** key to open the **Date/Time** dialog box. User can set Year, Month, Day, Hour, Minute and Second. Press **Up** and **Down** keys to choose menu items, **Left** and **Right** keys to modify the item contents.

! NOTE: If the imager is not used for a long period, the system clock may need reset due to the internal battery being depleted.

4.4.5 System setup

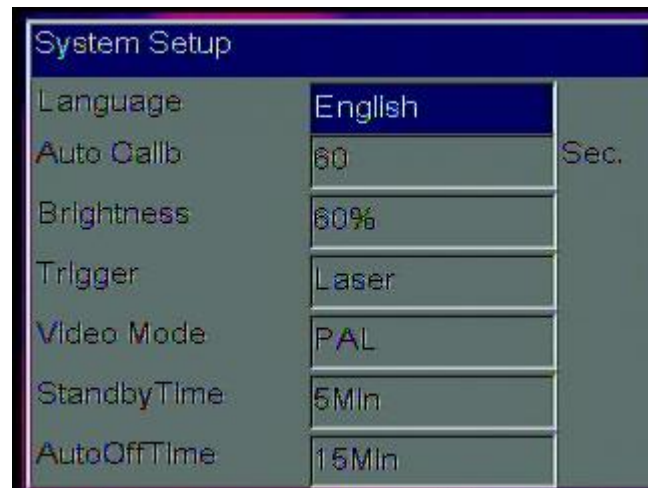

Press **Menu** key to activate the main menu. Select **Setup->Sys. Setup** and press **Confirm** key to open the **System Setup** dialog box. User can set Language, Auto calibration, LCD brightness, Trigger assignment, Video mode, Standby time and Auto off time. Press **Up** and **Down** keys to choose menu items, **Left** and **Right** keys to modify the item contents.

- **Language: Select system language from 11: English, Spanish, French, German, Italian, Portuguese, Korean, Japanese, Russian, Simplified Chinese and Traditional Chinese.**
- **Auto Calibration:** Select Auto Calibration and press right arrow key, **Auto Calib mode** dialogue box will pop up. User can select from 3 modes: **long, short** or **customize**. Customize can guide user to set the time interval for auto calibration. Range is **0**, which is Off and **30 to 600** in 1 second increments. Auto calibration is used to improve image quality and measurement accuracy during use.
- **LCD Brightness:** User can select the brightness of LCD display with choices being **20, 40, 60 80** and **100%**.
- **Trigger:** User can define the trigger key function from Laser, Spot Temp,

Area Temp, Save key

- **Laser:** Allows user to Turn on and turn off the laser sight.
 - **Spot Temp:** Adds or deletes Spot Measurement.
 - **Area Temp:** Adds or deletes Area Measurement.
 - **Save key:** Initiates the save routine.
- **Video Mode:** Allows selection of **PAL** or **NTSC** video output.
 - **Standby Time:** Allows user to select **None, 2, 5, 10** or **15** minutes.
If no button depressions are made during the set time, the camera will turn off the screen automatically, to prolong battery life. Press any key except power key to reactivate the screen. If set to **None**, the function is disabled.
 - **AutoOffTime:** Allows user to select **None, 2, 5, 10** or **15** minutes.
If no button depressions are made during the set time, the camera will turn off the main power automatically to prolong battery life. If set to **None**, the function is disabled. When **StandbyTime is** enabled, **AutoOffTime** will start calculating from StandbyTime.

4.4.6 System Info



Press **Menu** key to activate the main menu. Select **Setup->Sys. Info** and

press **Confirm** key to open the **System Information** dialog box. It displays the Model number, Serial number, Version number and Date of Manufacture.

4.4.7 Factory Default



30

It is used for resetting factory defaults. Press **Menu** key to activate the main menu. Select **Setup->Default** and press **Confirm** key to open the **Reset** dialog box. Press **Confirm** key to reset the factory default. Press **C** key to cancel the reset operation. Appendix B indicates the detailed factory default parameter table.

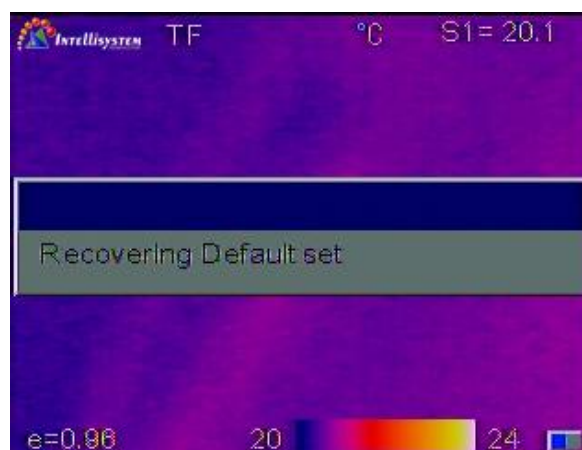

! NOTE: Default Reset function will delete all parameters defined by

user.

! NOTE: Restoring Default settings will NOT delete images stored on the TF card.

4.5 File

31

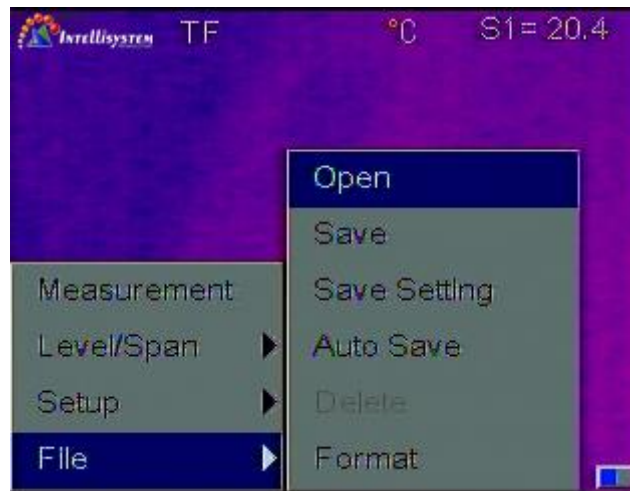

4.5.1 Open

Press **Menu** key to activate the main menu. Select **File->Open**, press **Confirm** key to open the saved images. Press **Left** and **Right** keys to change the images. Press **C** key to exit the opened image and return to measurement status. The imager will open the last image displayed or the last image saved, whichever occurred last.

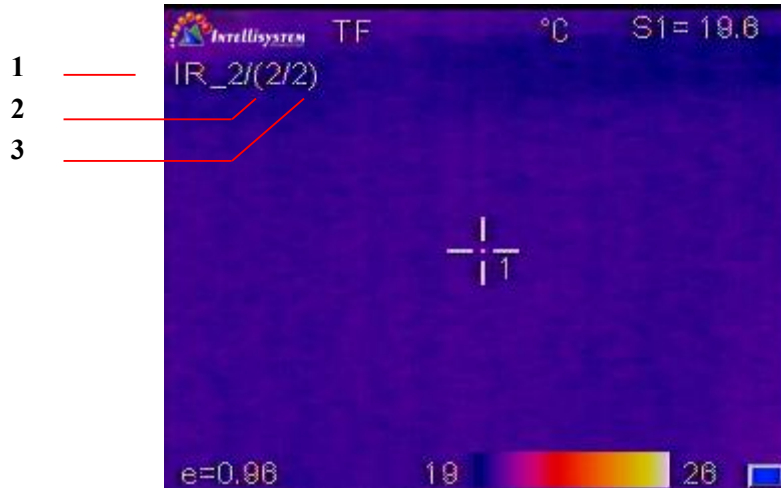

- [1] Current file name, created by Imager.
- [2] Current displayed image file number
- [3] Total number of images currently stored

4.5.2 Save

It is used for saving the image, performs the same functionality as the Save key. Press **Menu** key to activate the main menu. Select **File->Save**, press **Confirm** key to save the current image into the TF card or highlight **Cancel** and press **Confirm** key to cancel Save operation. Alternatively, the **C** key may be pressed to cancel. **Saving Data** will display.

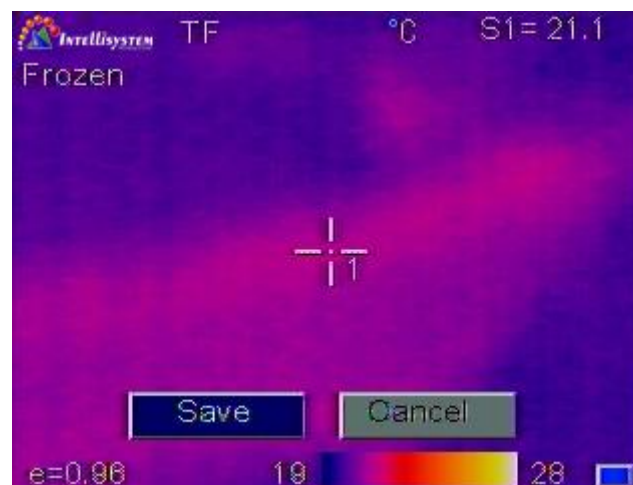

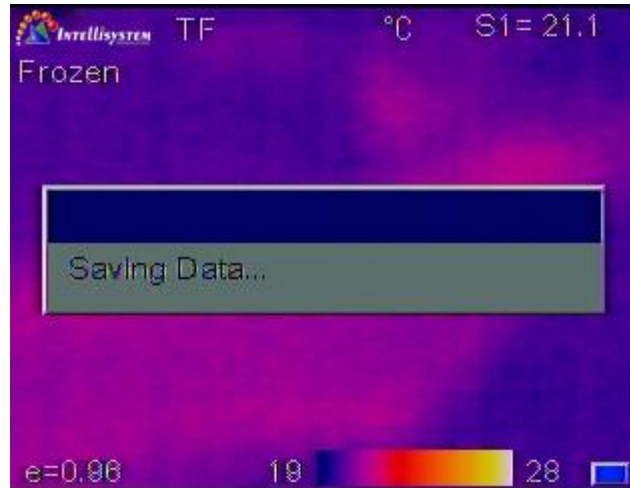

With **Voice Save** set in **Save Settings** menu, if Voice Save was **On**, Recording will start. Speak clearly into the microphone on the control panel. Record function allows up to 60 seconds of recording time and may be stopped at any time by pressing the **Confirm** key.



If the TF card is not installed, the display will prompt the user to install a SD card.

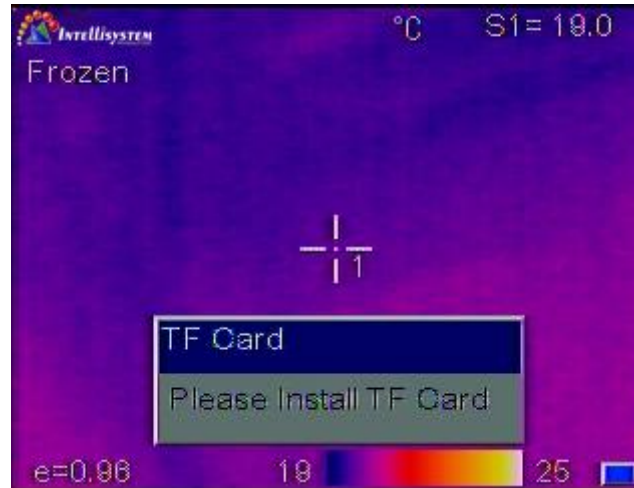

The Display will acknowledge when the TF card is installed properly.

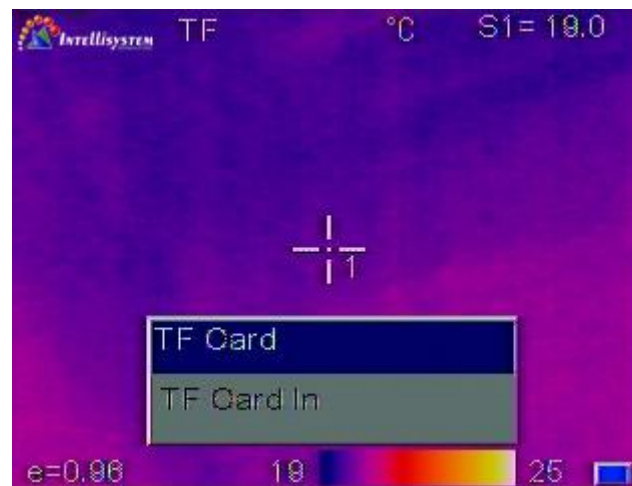

4.5.3 Auto Save

Auto Save allows the camera to automatically save images at a user-specified interval. Voice annotation is inactive with Auto Save. With Auto Save set to 0 the function is disabled. To enable, select 10 to 3600 seconds (1 hour), in 1-second increments. To set, press **Menu** key to activate the main menu. Select **File->Auto Save**, press **Confirm** key to display the Auto Save dialog box. Press **Left** and **Right** keys to set the values. Press the **Confirm** key to accept and recording timer will start saving images at the selected interval.



4.5.4 Delete

Used for deleting the image. When camera is in image replay mode, press **Menu** key to activate the main menu, select File->Delete, press **Confirm** key to pop out the below prompt box. Press **Confirm** key to delete the current opened image. If it has voice comment, it will be deleted together. Press **C** key to cancel the deletion.

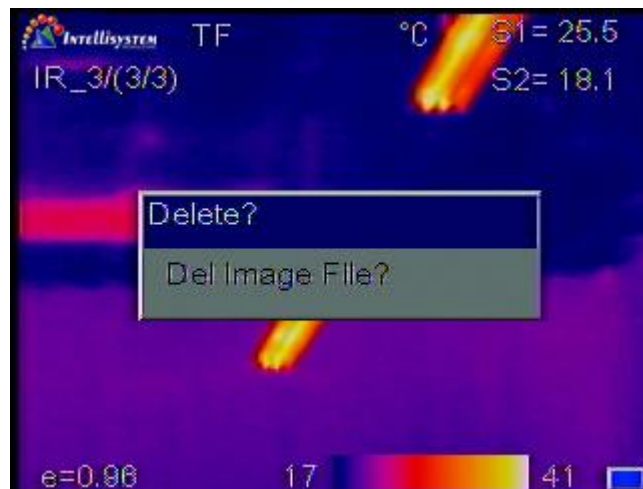

! CAUTION: Before deleting, make sure the file is not needed or already backed up. Files cannot be recovered after deletion.

4.5.5 Format

Format is used for formatting the TF card. Press **Menu** key to activate the main menu. Select File->Format and press **Confirm** key to pop up the below dialog box. Press **Confirm** key to do format; press **C** key to cancel the format.

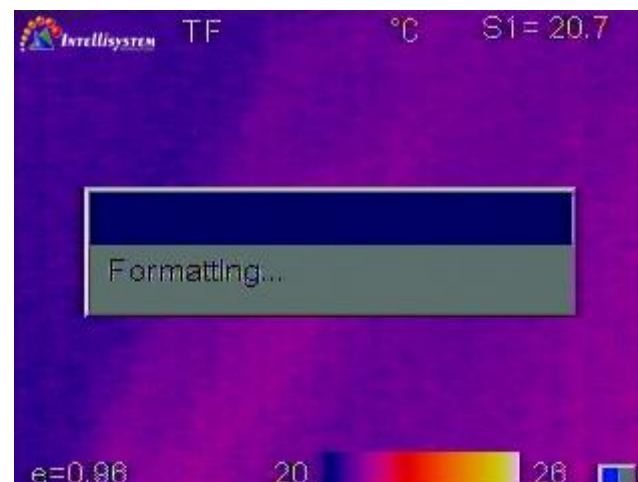

! CAUTION: Before formatting, make sure all files are not needed or already backed up. Data cannot be recovered after formatting. If formatting via PC, please use FAT16 format.

5 Technical specifications

Items		ThermalTronix TT-13T-HTI
Detector characteristics	Detector type	Un-cooled FPA micro-bolometer
	Array size/format	160×120
Image characteristics	Field of view/min focus distance	25°×19°/0.1m
	Spatial resolution (IFOV)	2.72mrad
	Thermal sensitivity	≤0.06°C@30°C
	Frame frequency	50/60Hz
	Focus	Manual
	Spectral range	8-14um
Image display	LCD display	3.5" TFT LCD, 640 x 480
Measurements	Temperature ranges	-20°C ~ +350°C
	Accuracy	± 2 °C or ± 2% of reading, Whichever is greater
	Measurement correction	Automatic / manual
	Measurement mode	1 movable spots, Hottest spot/coldest spot tracking, 1 movable areas (maximum, minimum and average temperatures), Alarm(voice, color)
	Image control	6 color palettes changeable
		Image adjustment Auto/manual gain and brightness
	Setup functions	Date/time, temperature unit, language
	Emissivity correction	Variable from 0.01 to 1.0
	Background temperature correction	Automatic corrections according to user input
Atmospheric transmission correction	Automatic correction according to user input object distance, humidity and temperature	
Image storage	Storage card	8G SD card, max 16G
	Storage mode	Manual/Auto single file saving
	File format	Thermal: JPEG with original thermal measurement data included
Power source	Battery type	Li-Ion, rechargeable
	Battery operating time	3 hours continuous operation

	Battery charging mode	Intelligent charger or power adaptor 12V(optional) to random charge
	Power saving	Auto-sleep and auto-shut down
	External power	10-15V DC
Environment	Operating temperature	-15°C ~ +50°C
	Storage temperature	-40°C ~ +70°C
	Humidity	Operating and storage: ≤90% non-condensing
	Encapsulation	IP54
	Drop test	2m
	Anti-shock	25G, IEC68-2-29
	Vibration resistance	2G, IEC68-2-6
Physical characteristics	Weight	980g
	Dimension	105*245*230mm
Interface	SD card slot	Micro SD card slot
	External DC input	YES
	Video output	YES
	USB	Image, measurement data transfer
	Tripod	1/4"-20-UNC

The information contained in this document is subject to change without notice.

Troubleshooting

Please follow the table below to diagnose and correct the problem. If problem still exists, please contact our service department.

Problem	Cause & Solution
The camera does not power on.	<ul style="list-style-type: none"> ● Battery not installed or installed incorrectly →Install battery or re-install battery ● Battery is out of power. →Change battery. ● "Power off" protection is enabled →Wait for 5 seconds and reboot.
The camera powers off automatically.	<ul style="list-style-type: none"> ● Battery is out of power. →Change battery ● Auto Off Time option is enabled →Set as None.
Battery depletion is too fast	<ul style="list-style-type: none"> ● Environmental temperature is too low ● Rechargeable battery is not charged completely. →Recharge the battery. ● Rechargeable battery is out of power completely and cannot be recharged. →Change to new battery.
No thermal image	<ul style="list-style-type: none"> ● Lens cover is not removed. →Remove lens cover. ● In image freeze status →Press C key to exit.
Thermal image is white-black.	<ul style="list-style-type: none"> ● White-black palette is selected →Select normal palette.

Appendix A

Common material emissivity (FYI)

Material	Surface	Temperature°C	Emissivity (ϵ)
Aluminum	Non- oxidized	100	0.20
	Oxidized	100	0.55
Brass	Burnished to Brown	20	0.40
	Dull luster	38	0.22
	Oxidized	100	0.61
Copper	Seriously Oxidized	20	0.78
Iron	Oxidized	100	0.74
	Rusty	25	0.65
Cast iron	Oxidized	200	0.64
	Non- Oxidized	100	0.21
Wrought iron	Quarry-faced	25	0.94
	Polished	38	0.28
Nickel	Oxidized	200	0.37
Stainless steel	Oxidized	60	0.85
Steel	Oxidized	200	0.79
Common brick	Surface	20	0.93
Concrete	Surface	20	0.92
Glass	Polished plate	20	0.94
Lacquer	White	100	0.92
	Black	100	0.97
Carbon	Smoke black	25	0.95
	Candle soot	20	0.95
	Rough lead surface	20	0.98
Oil paint	Value of 16 colors	100	0.94
Paper	White	20	0.93
Sand soil	Surface	20	0.90
Timber	Dressed	20	0.90
Water	Distilled water	20	0.96
Skin	Human	32	0.98
Ceramic	Thin	21	0.90
	Thick	21	0.93

Appendix B

Factory default parameter setting table

Table.1 Measurement temperature setting table

Parameter	Value	
	TT-13T-HTI	
Temperature Range	-20 ~ 350°C	-20 - 180°C
Lens	Standard	
Temp Unit	°C	
Ref Type	Off	
Ref Temp	30°C	

41

Table.2 Measurement temperature correction table

Parameter	Value
Emissivity	0.96
TCorrect	0°C
TAmbient Temp	Off

Table.3 Analysis setting table

Parameter	Value
Temp Alarm	Off
Alarming Temp	50.0°C
Alarming Color	None
Isotherm Color	Off
Isotherm Temp	50.0°C
Isotherm Width	1.0°C

Table.4 System setting table

Parameter	Value
Language	English
Brightness	60S
Auto Calib	60%
Video Mode	Laser sight
Quick Access	NTSC
StandbyTime	5 mins
AutoOffTime	15 mins