

IT-ES308-IU-4F

8-ports Unmanaged Industrial Ethernet Switch Hardware Installation Guide

1

Introduction:

IT-ES308-IU-4F are a smart plug-and-play industrial Ethernet switch, which can provide economical solution for your Ethernet. Its dustproof fully sealed structure(protective case of IP30 level), over-current, over-voltage and EMC protected redundant double power input as well as built-in intelligent alarm design can help system main tenancy personnel monitor the network operation, which can work reliably in harsh and dangerous environment.

IT-ES308-IU-4F supports 4 TP ports and 4 fiber ports (IT-ES308-IU-4F: 4-ports 10/100Base-Tx, 4-ports 100Base-FX). TP (RJ45) support 10/100Base-T(X), Full/Half duplex mode, and auto MDI/MDI-X connection; 100BaseFX supports single-/multi-mode, SC/ST/FC connector for optional.

Packing List:

The IT-ES308-IU-4F switch is shipped with following items.

1. Ethernet switch IT-ES308-IU-4F (plus terminal block) x1
2. Hardware Installation Guide x1
3. Product Warranty Statement x1
4. DIN-Rail setting fittings

Features:

1. Advanced Ethernet switch technical
2. IEEE802.3/802.3u/802.3x/802.3d, store and forward
3. 10/100M, F/H duplex, MDI/MDI-X auto negotiation
4. Broadcast storm protection
5. Relay output warning for power failure and port break alarm
6. Redundant 24VDC power input (12V ~ 48VDC)
7. Designed for industrial applications. IP30 protection, Rugged high-strength metal case

Panel Layout:

IT-ES308-IU-4F (4 TP ports and 4 fiber ports):

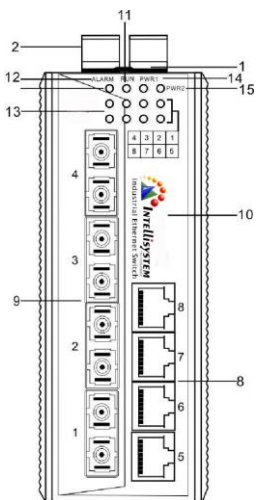

Front panel.

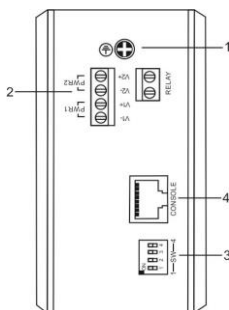

Top panel

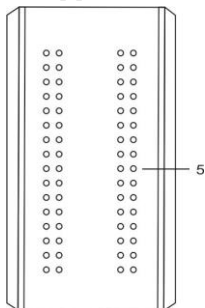

Bottom panel

1. Grounding screw
2. Terminal block (4 bits) for PWR1/PWR2 input, terminal block (2 bits) for relay output
3. DIP switch (ON is enable)

4. Program loading port
5. Heat dissipation orifices
6. DIN-Rail locating kit
7. Screw hole for wall mounting kit
8. 10/100Base-T(X) port
9. 100Base-FX ports
10. Model name
11. Facility run indication LED
12. System alarm indication LED
13. Port indication LED
14. Power input PWR1 LED
15. Power input PWR2 LED

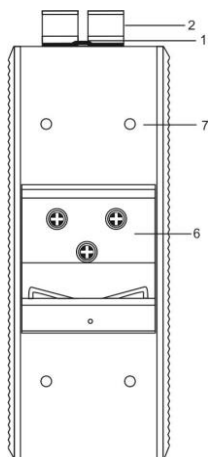

Back panel

3

Units (mm)

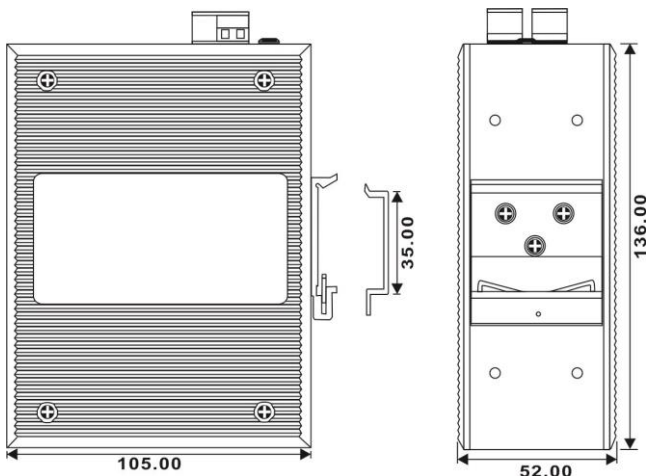

Communication connector:

IT-ES308-IU-4F have 4 10/100BaseT(X) Ethernet ports (RJ45) and 4 100BaseFX (SC/ST/FC type connector) fiber ports.

10/100BaseT(X) Ethernet port

The pin out of RJ45 port display as below, connect by UTP or STP. The connect distance is no more than 100m. 100Mbps is used 100 Ω of UTP 5, 10Mbps is used 100 Ω of UTP 3, 4, 5.

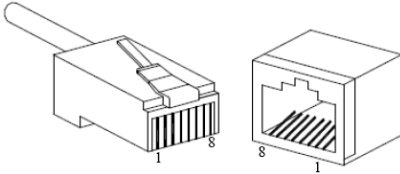

RJ45 port support automatic MDI/MDI-X operation. Can connect the PC, Server, Converter and HUB .Pin 1,2,3,6 Corresponding connection in MDI. 1→3, 2→6, 3→1, 6→2 are used as cross wiring in the MDI-X port of Converter and HUB. . 10Base-T/100Base-TX are used in MDI/MDI-X, the define of Pin in the table as below.

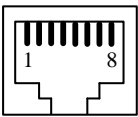

NO.	MDI signal	MDI-X signal
1	TX+	RX+
2	TX-	RX-
3	RX+	TX+
6	RX-	TX-
4,5,7,8	—	—

Note: “TX±”transmit data±, “RX±”receive data±, “—”not use

MDI (straight-through cable)

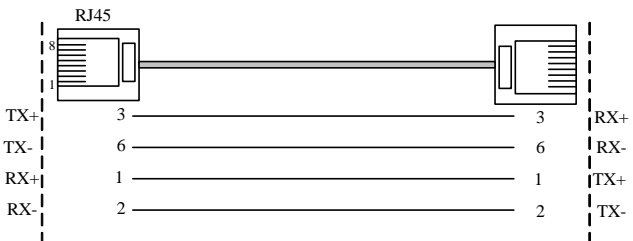

MDI-X (Cross-over cable)

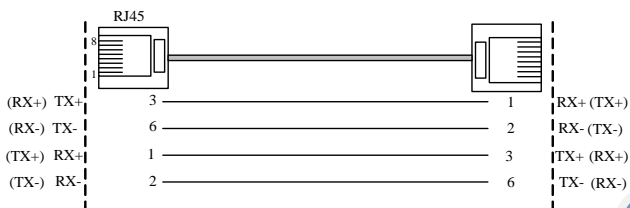

100BaseFX port

100Base-FX full-duplex SM or MM port, SC/ST/FC type .The fiber port must be used in pair, TX (transmit) port connect remote switch's RX (receive) port; RX (receive) port connect remote switch's TX (transmit) port.

The optical fiber connection supports the line to instruct enhance the reliability of network effectively.

Suppose: If you make your own cable, we suggest labeling the two sides of the same line with the same letter (A-to-A and B-to-B, shown as below, or A1-to-A2 and B1-to-B2).

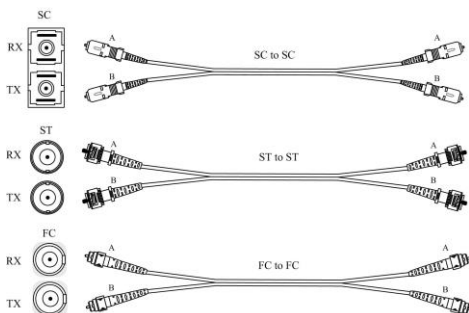

LED Indicator:

LED indicator light on the front panel of IT-ES308-IU-4F .the function of each LED is described in the table as below.

System indication LED		
LED	State	Description
PWR1	ON	Power1 is being supplied to
	OFF	Power1 is not being supplied to
PWR2	ON	Power2 is being supplied to
	OFF	Power2 is not being supplied to
Alarm	ON	When the alarm is enabled, power and the port's link is inactive.
	OFF	Power and the port's link is active, not alarm
Run	ON	Common straight link mode
	OFF	disable
Link/ACT 1~8	ON	TP port is active
	Blinking	Data is being transmitted
	OFF	TP port is inactive

Relay contact:



RELAY

Relay access terminals located on the top panel, the terminal is a

set of device alarm relay normally open contact, no alarm in the normal state when the open state, when there is no warning message when it is closed. IT-ES308-IU-4F to support a relay alarm output, external warning light or alarm buzzer, also can add other digital acquisition device so that in the event of an alarm to alert the operator when a timely manner.

Power Input:

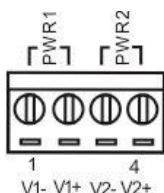

IT-ES308-IU-4F have redundant power input, provides one terminal block (4 bits) for PWR1 and PWR2 input. The redundant power can be used single and used two self-governed power to supply to the system, PWR1 and PWR2 input at the same time, when neither of these two power fails, the other power acts as a backup, and automatically supplies power needs, ensure running Ethernet reassuring.

Switch Settings:



Top panel provides four DIP switch function is set (ON to enable effective), 1 (ISP) for the program to load the serial port selection, 2 to restore the factory settings; 3, 4 are reserved.

Changing the DIP switch status, must re-power.

Installation:

Before installation, confirm that the work environment meet the installation require, including the power needs and abundant space. Whether it is close to the connection equipment and other equipment are prepared or not.

Installation require as below

1. Avoid in the sunshine, keep away from the heat fountainhead or the area where in intense EMI.
2. Examine the cables and plugs that installation requirements.
3. Examine whether the cables be seemly or not (less than 100m) according to reasonable scheme.
4. Screw, nut, tool provide by yourself.
5. Power need: Redundant, dual 24VDC (12VDC~48VDC)
6. Environment: -40 to 75°C

Storage Temperature: -45°C to 85°C

Relative humidity 10% to 95%

DIN-Rail Installation

In order to use in industrial environments expediently, IT-ES308-IU-4F adopt 35mm DIN-Rail installation, the installation steps as follows:

1. Examine the DIN-Rail attachment
2. Examine DIN Rail whether be firm and the position be suitability or not.
3. Insert the top of the DIN-Rail into the slot just below the stiff metal spring.
4. The DIN-Rail attachment unit will insert into place as shown below.

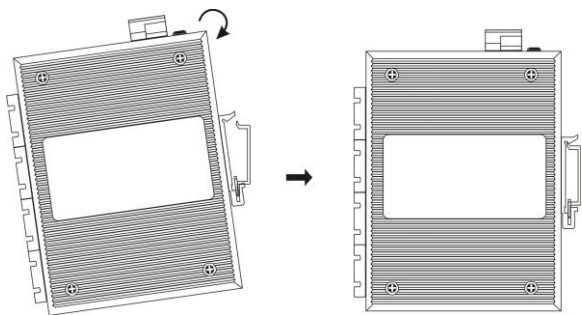

Wiring Requirements:

Be sure to disconnect the power cord before installing and/or wiring your Ethernet Switch.

Calculate the maximum possible current in each power wire and common wire. Observe all electrical codes dictating the maximum current allowable for each wire size. If the current goes above the maximum ratings, the wiring could overheat may causing serious damage to your equipment. You should also pay attention to the following items:

1. Use separate path to route wiring for power and devices. If power wiring and device wiring paths must cross, make sure the wires are perpendicular at the intersection point.
2. NOTE: Do not run signal or communications wiring and power wiring in the same wire conduit. To avoid interference, wires with different signal characteristics should be routed separately.
3. You can use the type of signal transmitted through a wire to determine which wires should be kept separate. The rule of thumb is that wiring that shares similar electrical characteristics can be bundled together.
4. Keep input and output wiring separated. It is strongly advised

that you label wiring to all devices in the system when necessary.

Specifications:

Interfaces

RJ45 Ports: 10/100BaseT(X) auto connection, F /H duplex or force work mode, and support MDI/MDI-X connection

Fiber Ports: 100BaseFX ports (SC/ST/FC connector, optional)
Single-mode: 20, 40, 60, 80, 100,120Km, optional
Multi-mode: 2Km, optional

Wavelength: 850nm, 1310 nm, 1550nm

Alarm output interface: One relay alarm output. Support power, port link and network alarm

Indicator: Power, Port link, abnormality alarm indication

Technology

Standards: IEEE802.3, IEEE802.3x, IEEE802.3u

Forwarding and Filtrate Rate: 148810pps

Processing type: Store and Forward

System exchange bandwidth: 1.6G

Relay

Current carrying capacity: 1A@30VDC

Power

Input Voltage: 24VDC (12VDC~48VDC)

Overload Current Protection

Support dual power backup

Mechanical

Dimensions: 136mm × 52mm × 105mm (H × W × D)

Casing: IP30 protection, Metal case

Installation: DIN-Rail

Weight: 900g

Environmental

Operating Temperature: -40 to 75°C

Storage Temperature: -45 to 85 °C

Ambient Relative Humidity: 10% to 95% (non-condensing)

Approvals

EMI: FCC Part 15, CISPR (EN55022) class A

EN61000-4-2 (ESD), Level 4

EN61000-4-3 (RS), Level 3

EN61000-4-4 (EFT), Level 4

EN61000-4-5 (Surge), Level 4

EN61000-4-6 (CS), Level 4

EN61000-4-8, Level 5

Shock: IEC 60068-2-27

Free Fall: IEC 60068-2-32

Vibration: IEC 60068-2-6

Warranty: 5 years

Certifications:

