

IT-ES215-IU series

Unmanaged Industrial Ethernet Switch Hardware Installation Guide

【Introduction】

IT-ES215-IU series is a type of industrial Ethernet switch, it supports IEEE802.3, IEEE802.3u, IEEE802.3x standard, can provide economical solution for your network connection. IP40 grade protection ensures reliable work in terrible environment. LED indicator is helpful to monitor and control the status of network connection.

IT-ES215-IU series can provide 3~5 Ethernet ports and 0~2 fiber ports(IT-ES215-IU: 5 Ethernet ports; IT-ES215-IU-1F: 4 Ethernet ports, 1 fiber port; IT-ES215-IU-2F: 3 Ethernet ports, 2 fiber ports) Ethernet port (RJ45) supports 10/100Base-T(X), full/half duplex, MDI/MDI-X auto-connection; fiber port is 100Base-FX, multi-mode (M)/ single-mode(S), SC/ST optional.

【Packing List】

The IT-ES215-IU series switch is shipped with following items.

- IT-ES215-IU Ethernet switch(Plus Terminal Block) ×1
- Hardware Installation Guide ×1
- DIN-Rail setting fittings(wall mounting for optional)

The equipment built-in precision devices, please note gently, avoiding excessive vibration to avoid affecting device performance. If you find the equipment was damaged in transit or any parts are missing, please inform our company or the dealer, we will give you proper solution as soon as possible.

【Features】

- Support IEEE802.3, IEEE802.3u, IEEE802.3x Standard
- Support Auto-Negotiation technology, full/half duplex mode
- Plug-and-play, MDI/MDI-X auto connection
- Store and forward
- LED light indicates the status of network
- 12~48VDC dual power supply
- -40~75°C operating temperature
- Industrial grade design, IP40 protection, metal shell.

【Panel Layout】

IT-ES215-IU series

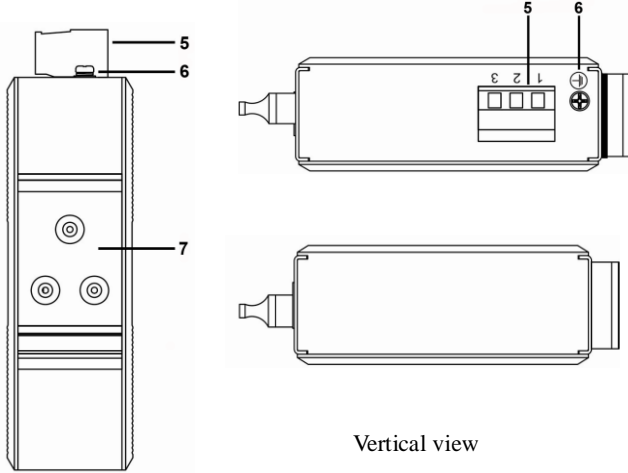

Back view

Vertical view

IT-ES215-IU

1. Power indicator
2. Ethernet port indicator
3. 10Base-T/100Base-TX port
5. Power input terminal block (3 bits)
6. Ground screw
7. DIN-Rail mount

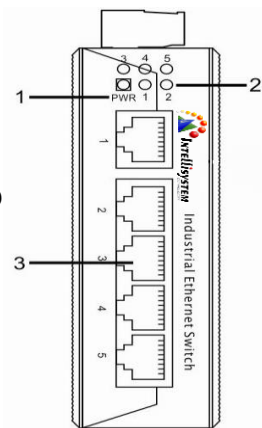

IT-ES215-IU-1F

1. Ethernet port indicator
2. Power indicator
3. 100Base-FX fiber port
4. 10Base-T/100Base-TX port
5. Power input terminal block (3 bits)
6. Ground screw
7. DIN-Rail mount

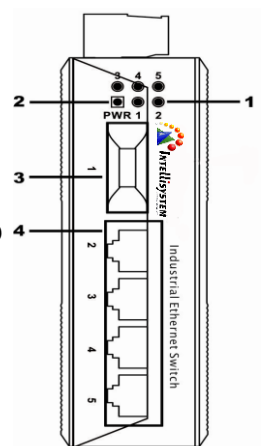

IT-ES215-IU-2F

1. Power indicator
2. Ethernet port indicator
3. 100Base-FX fiber port
4. 10Base-T/100Base-TX port
5. Power input terminal block (3 bits)
6. Ground screw
7. DIN-Rail mount

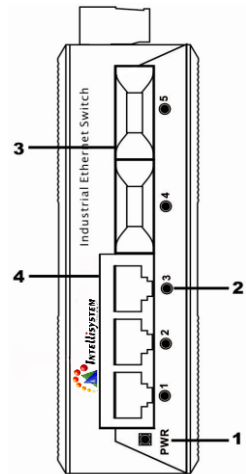

【Dimensions】

Unit (mm)

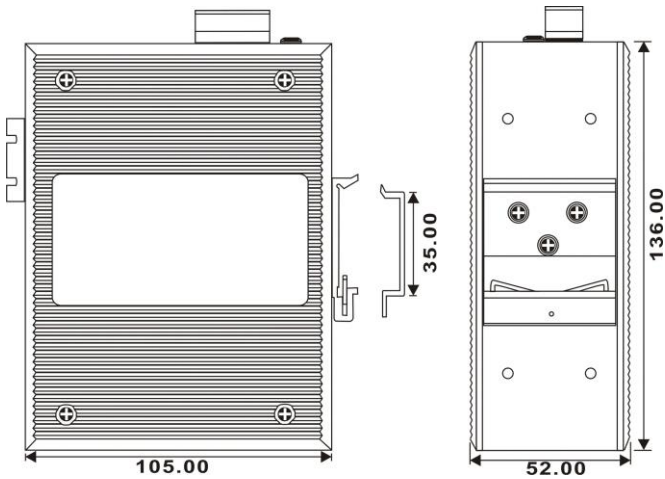

【Communication Connector】

IT-ES215-IU series industrial Ethernet switch provides 3~5 10/100BaseT(X) Ethernet ports (RJ45) and 0~2 100Base-FX fiber ports (SC/ST optional).

10/100BaseT(X) Ethernet port

The pin define of RJ45 port display as below, connect by UTP or STP. The connect distance is no more than 100m. 100Mbps is used 100Ω of UTP 5, 10Mbps is used 100Ω of UTP 3, 4, 5.

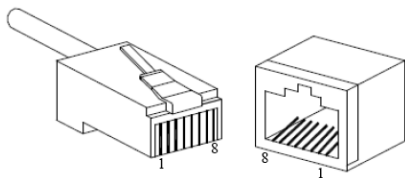

RJ 45 port support automatic MDI/MDI-X operation. Can connect the PC, Server, Converter and HUB .Pin 1,2,3,6 Corresponding connection in MDI. 1→3, 2→6, 3→1, 6→2 are used as cross wiring in the MDI-X port of Converter and HUB. 10Base-T/100Base-TX are used in MDI/MDI-X, the define of Pin in the table as below.

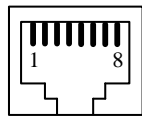

NO.	MDI signal	MDI-X signal
1	TX+	RX+
2	TX-	RX-
3	RX+	TX+
6	RX-	TX-
4, 5, 7, 8	—	—

Note: “TX±” Transmit Data±, “RX±” Receive Data±, “—” Not use.

MDI (straight-through cable)

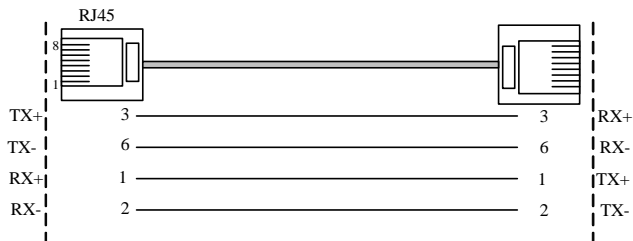

MDI-X (Cross over cable)

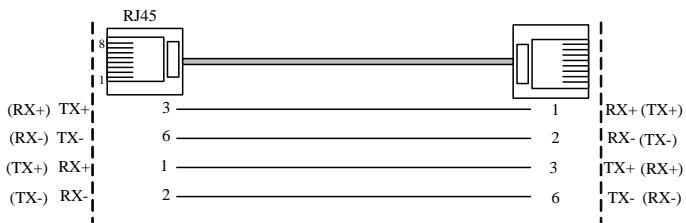

100BaseFX port

100Base-FX full-duplex SM or MM port, SC/ST type .The fiber port must be used in pair, TX (transmit) port connect remote switch's RX(receive) port; RX(receive) port connect remote switch's TX(transmit) port.

The optical fiber connection supports the line to instruct enhance the reliability of network effectively.

Suppose: If you make your own cable, we suggest labeling the two sides of the same line with the same letter (A-to-A and B-to-B, shown as below, or A1-to-A2 and B1-to-B2).

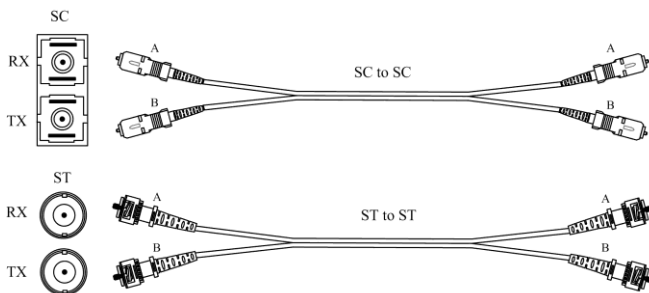

【LED Indicator】

LED indicator light on the front panel of IT-ES215-IU Series .the function of each LED is described in the table as below.

System indication LED		
LED	State	Description
PWR (green light)	ON	Power is being supplied to power input PWR input
	OFF	Power is not being supplied to power input PWR input
Link (green)	ON	FX port is active
	OFF	FX port is inactive
	Blinking	Data is being transmitted

【Power Input】

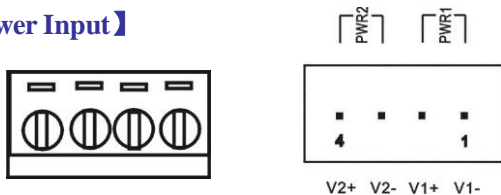

IT-ES215-IU series Ethernet switch provides 4 bits industrial terminal blocks (V1-, V1+), (V2-, V2+), V-, V+ is 12~48VDC power input.

【Installation】

Before installation, confirm that the work environment meet the installation require, including the power needs and abundant space. Whether it is close to the connection equipment and other equipment are prepared or not.

1. Avoid in the sunshine, keep away from the heat fountainhead or the area where in intense EMI.
2. Examine the cables and plugs that installation requirements.
3. Examine whether the cables be seemly or not (less than 100m) according to reasonable scheme.
4. Screw, nut, tool provide by yourself.
5. Power need: 24VDC power inputs (12~48DC)
6. Environment: -40°C to 75°C

Relative humidity 10% to 95%

DIN Rail Installation

In order to use in industrial environments expediently, IT-ES215-IU series adopt 35mm DIN-Rail installation, the installation steps as below,

1. Examine the DIN-Rail attachment
2. Examine DIN Rail whether be firm and the position be suitability or not.
3. Insert the top of the DIN-Rail into the slot just below the stiff metal spring.
4. The DIN-Rail attachment unit will snap into place as shown below.

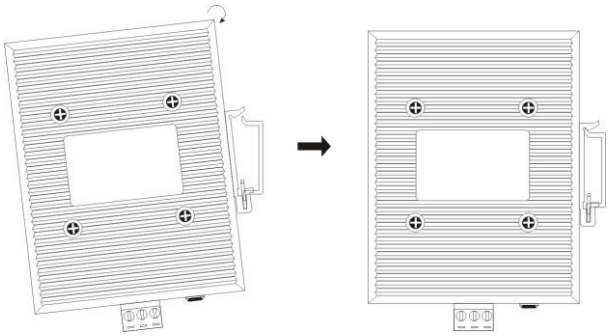

Wiring Requirements

Cable laying need to meet the following requirements,

1. It is needed to check whether the type, quantity and specification of cable match the requirement before cable laying;
2. It is needed to check the cable is damaged or not, factory records and quality assurance booklet before cable laying;
3. The required cable specification, quantity, direction and laying position need to match construction requirements, and cable length depends on actual position;
4. All the cable cannot have break-down and terminal in the middle;
5. Cables should be straight in the hallways and turning;
6. Cable should be straight in the groove, and cannot beyond the groove in case of holding back the inlet and outlet holes. Cables should be banded and fixed when they are out of the groove;
7. User cable should be separated from the power lines. Cables, power lines and grounding lines cannot be overlapped and mixed when they are in the same groove road. When cable is too long, it cannot hold down other cable, but structure in the middle of alignment rack;
8. Pigtail cannot be tied and swerved as less as possible. Swerving radius cannot be too small (small swerving causes terrible loss of link). Its banding should be moderate, not too tight, and should be separated from other cables;
9. It should have corresponding simple signal at both sides of the cable for maintaining.

【Specifications】

Technology

Standard: IEEE802.3, IEEE802.3u, IEEE802.3x

Transmit Rate: 148810pps

Max Rate of Filtrate: 148810pps

Processing type: Store and Forward

MAC address: 2K

Interfaces

RJ45 port: 10/100BaseT(X) auto connection, Full /Half duplex or force work mode, and support MDI/MDI-X connection

Fiber port: 100BaseFX ports (SC/ST connector, optional)

Single-mode: 20, 40, 60, 80, 100,120Km, optional

Multi-mode: 2Km, optional

Wavelength: 850nm, 1310nm, 1550nm

Power

24VDC power input (12~48VDC)

Consumption is less than 2.7W

Overload Current Protection

IT-ES215-IU

No-load consumption: 0.5W@24VDC

Full-load consumption: 1.2W@24VDC

IT-ES215-IU-1F

No-load consumption: 1.2W@24VDC

Full-load consumption:2.0W@24VDC

IT-ES215-IU-2F

No-load consumption: 2.0W@24VDC

Full-load consumption:2.6W@24VDC

Mechanical

Shell: IP40 protection, metal case

Installation: Wall or DIN Rail Mounting

Dimensions (L*H*D): 136 mm×105mm×52mm

Working environment

Operating Temperature: -40~75°C

Storage Temperature: -40~85°C

Relative Humidity: 5%~95% (non-condensing)

Approvals

EMI: FCC Part 15, CISPR (EN55022) class A

EMS: EN61000-4-2 (ESD), Level 4

EN61000-4-3 (RS), Level 3

EN61000-4-4 (EFT), Level 4

EN61000-4-5 (Surge), Level 4

EN61000-4-6 (CS), Level 3

EN61000-4-8, Level 5

Shock: IEC 60068-2-27

Free fall: IEC 60068-2-32

Vibration: IEC 60068-2-6

Warranty: 5 years

Certification:

CE, FCC, RoHS, UL508 (Pending)