

IT-ES206-IU-2GS-P (12~48VDC)

Gigabit Unmanaged Industrial Ethernet switch

User manual

【Summarize】

IT-ES206-IU-2GS-P (12~48VDC) is a kind of industrial, unmanaged, gigabit Ethernet switch. It supports 4 port 10Base-T/100Base-TX Ethernet port and 2 port 1000Base-X SFP fiber port, no fan, low consumption design, working function more steadily. It accords with FCC, CE standard, industrial design requirement, it can work steadily in -40°C~75°C working temperature, it can provide reliable and quickly solution for your Ethernet device.

【Packing List】

The first time use this product, please check the packaging is intact or not and the attachment is complete or not at first.

- IT-ES206-IU-2GS-P(12~48VDC) x1
- User manual x1
- Certificate x1
- Warranty card x1
- DIN-rail kit x1

If you find that the device is damaged or any parts of it is missing during transportation, please notify the Company or the Company's distributor, we will give you proper solution as soon as possible.

【Features】

- Support IEEE802.3/IEEE802.3u/IEEE802.3x/IEEE802.3z store and forward
- Support 4 port 10Base-T/100Base-TX/1000 Base-TX and
2 port 1000Base-X SFP gigabit port
- Ethernet port support full/half duplex mode, MDI/MDI-X
- Support 12~48VDC power input, built-in overcurrent protection, Reverse connection protection
- Working temperature:-40°C~75°C
- No fan, low consumption, Industrial design standard
- IP40 protection grade, high strength iron shell, DIN-rail mount

【Panel Layout】

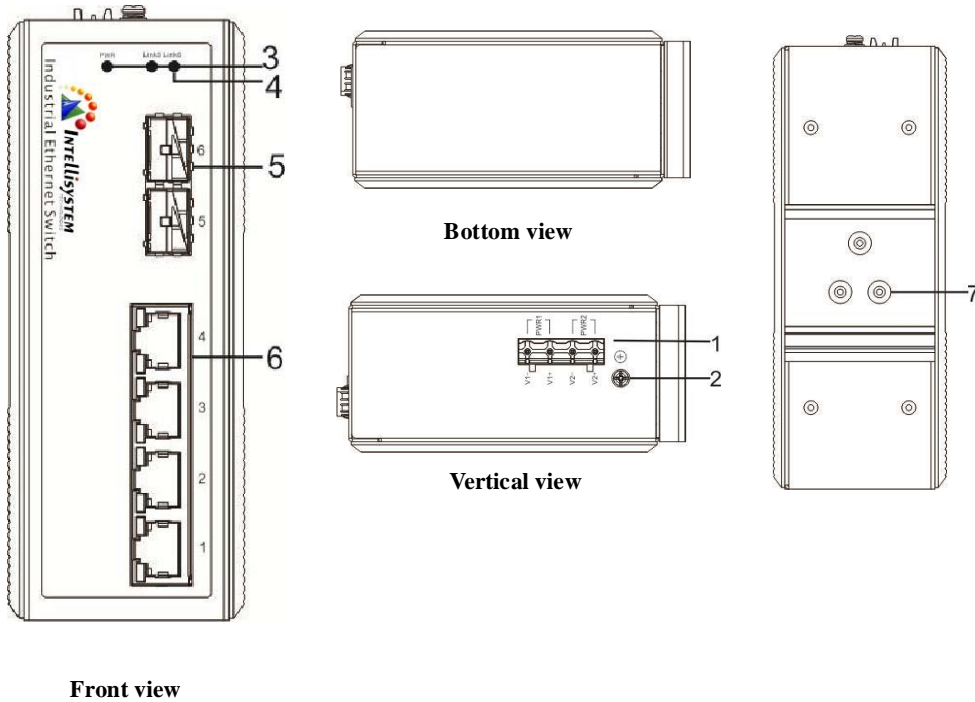

- 1、 4 bit power input terminal block
- 2、 Ground screw (Protect ground)
- 3、 Power indicator (PWR1/PWR2)
- 4、 Fiber port connection indicator (G1/G2)
- 5、 1000Base-X SFP fiber port
- 6、 Ethernet port connection indicator
- 7、 Din-rail mount

【Dimensions】

Unit (mm)

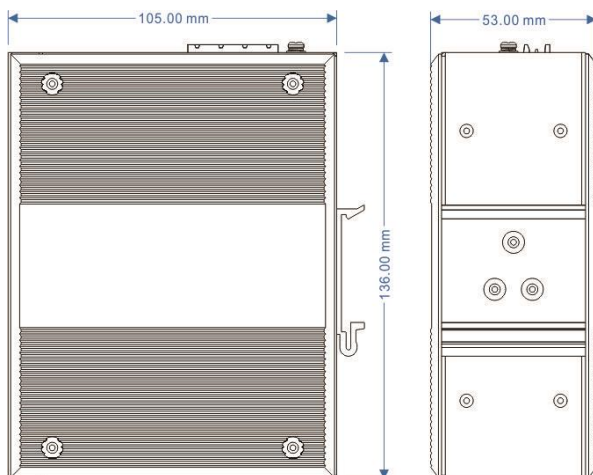

Intellisystem Technologies S.r.l.

Via Augusto Murri, 1 - 96100 Siracusa - Phone +39 (0)931-1756256 / +39 (0)2-87167549 - Mobile (+39) 335 1880035
 em@il: info@intellisystem.it WEB: <http://www.intellisystem.it>

【Power input】

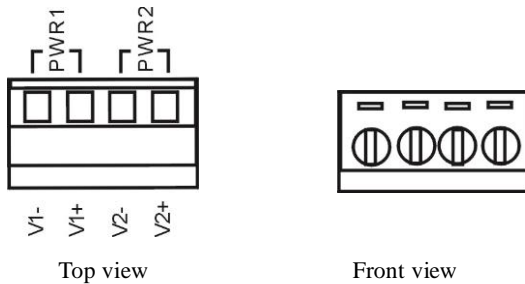

IT-ES206-IU-2GS-P(12~48VDC) top panel provided 4 bit industrial terminal block, power input is 24VDC(12~48VDC) , the sign of the terminal block is V1-, V1+, V2-, V2+, it is redundant power input, both of them are 12~48VDC

IT-ES206-IU-2GS-P(12~48VDC) DC power input had redundant function, provided PWR1 and PWR2 power input, can use for single, and can connect 2 separately power supply system, use 1 pair terminal block connect the device at the same time. If one of the power system broke, the device can work uninterruptible, built-in overcorrect protection, Reverse connection protection

Note: 1, Power ON: please insert the power cable's terminal block into device's power pot at first and then insert the power supply.
2, Power OFF, please pluck the plug of the power supply and then strike the terminal block parts.

【Communication interface】

IT-ES206-IU-2GS-P (12~48VDC) provided 4 port 10Base-T/ 100 Base -TX and 2 port 1000Base-X SFP gigabit port

10/100BaseT(X) Ethernet port

The pin out of RJ45 port display as below, connect by UTP or STP. The connect distance is no more than 100m. 100Mbps is used 120 Ω of UTP 5, 10Mbps is used 120 Ω of UTP 3, 4, 5.

RJ 45 port support automatic MDI/MDI-X operation. Can connect the PC, Server, Converter and HUB .Pin 1,2,3,6 Corresponding connection in MDI. 1→3, 2→6, 3→1, 6→2 are used as cross wiring in the MDI-X port of Converter and HUB. 10Base-T/100Base-TX are used in MDI/MDI-X, the define of Pin in the table as below.

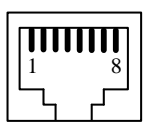

| NO. | MDI signal | MDI-X signal |
|---------|------------|--------------|
| 1 | TX+ | RX+ |
| 2 | TX- | RX- |
| 3 | RX+ | TX+ |
| 6 | RX- | TX- |
| 4,5,7,8 | — | — |

Note: "TX±"transmit data±, "RX±"receive data±, "—"not use

MDI (straight-through cable)

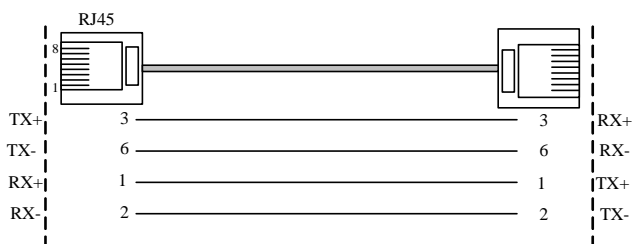

MDI-X (Cross over cable) :

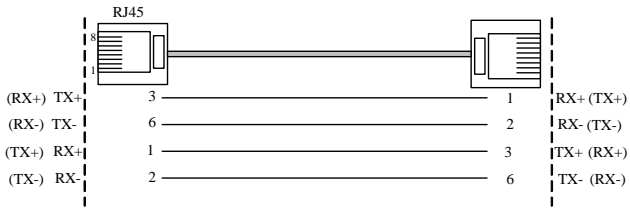

MDI/MDI-X self-adaptation function can let user did not think about the type of Ethernet cable (Through line or cross wire), can connect IT-ES206-IU-2GS-P(12~48VDC) by through line or cross wire directly.

1000BaseSFP port (mini-GBIC)

IT-ES206-IU-2GS-P (12/48VDC)'s 1000BaseSFP port adopted gigabit mini-GBIC optic fiber, can choice different type fiber according to different transfer distance, fiber port must used for pair, TX port is fiber transmit side, connect to other device's RX receive side, RX port is fiber receive side, connect to other device's TX transmit side. Fiber port support off-line indicator, can effective increase the reliability of network running.

Suggestion: please make a sign for the optic fiber (Figure as follows: A-A, B-B) , easy to use

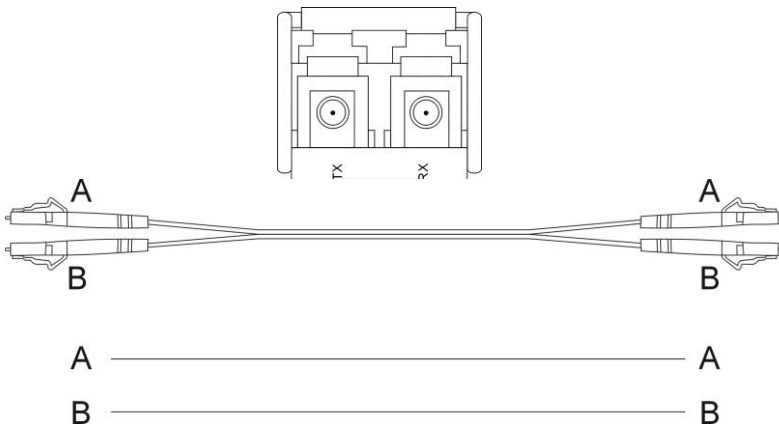

【LED Indicators】

LED indicator in front panel of IT-ES206-IU-2GS-P (12/48VDC) monitor working status, it is convenience to find the problem, and the function of each LED is described in the table as below.

| LED system statue | | |
|------------------------------------|----------|--|
| LED | Statue | Description |
| PWR (Green) | ON | PWR2 connect and running normal |
| | OFF | Power supply have no connection or unwonted |
| Link5、6 | ON | Fiber port made effective connection |
| | Blinking | Fiber port is in active statue |
| | OFF | Fiber port did not make effective connection |
| Each RJ45 port with two LED lights | | |
| 10/100M (Green) | ON | 100M mode (100Base-TX) |
| | OFF | 10M mode (10Base-TX) |
| Link/ACT (Green) | ON | The port has been the establishment of an effective network connection |
| | Blinking | The port is in a running state of network |
| | OFF | The port is not the establishment of an effective network connection |

【Installation】

Before installation, confirm that the work environment meet the installation require, including the power needs and abundant space. Whether it is close to the connection equipment and other equipment are prepared or not.

Installation require as below

1. Avoid in the sunshine, keep away from the heat fountainhead or the area where in intense EMI.
2. Examine the cables and plugs that installation requirements.
3. Examine whether the cables be seemly or not (less than 100m) according to reasonable scheme.
4. Screw, nut, tools provide by yourselves.
5. Power need: power inputs (12~48DC)
6. Environment: -40°C to 75°C
 Storage Temperature: -40°C to 85°C
 Relative humidity 10% to 95%

DIN-Rail Installation

In order to use in industrial environments expediently, IT-ES206-IU-2GS adopt 35mm DIN-Rail installation, the installation steps as follows:

1. Examine the DIN-Rail attachment
2. Examine DIN Rail whether be firm and the position be suitability or not.
3. Insert the top of the DIN-Rail into the slot just below the stiff metal spring.
4. The DIN-Rail attachment unit will snap into place as shown below.

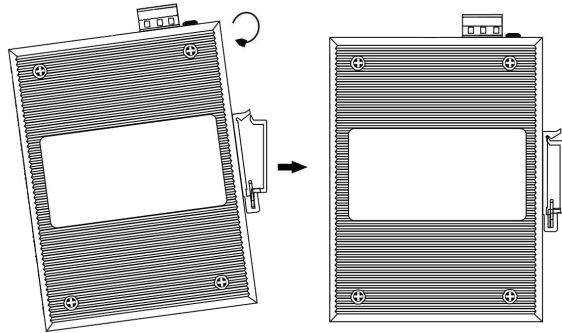

Wiring Requirements

Wiring need to meet the following requirements:

- It is needed to check whether the type, quantity and specification of cable match the requirement before cable laying;
- It is needed to check the cable is damaged or not, factory records and quality assurance booklet before cable laying;
- The required cable specification, quantity, direction and laying position need to match construction requirements, and cable length depends on actual position;
- All the cable cannot have break-down and terminal in the middle;
- Cables should be straight in the hallways and turning;
- Cable should be straight in the groove, and cannot beyond the groove in case of holding back the inlet and outlet holes. Cables should be banded and fixed when they are out of the groove;
- User cable should be separated from the power lines. Cables, power lines and grounding lines cannot be overlapped and mixed when they are in the same groove road. When cable is too long, it cannot hold down other cable, but structure in the middle of alignment rack;
- Pigtail cannot be tied and swerved as less as possible. Swerving radius cannot be too small (small swerving causes terrible loss of link). Its banding should be moderate, not too tight, and should be separated from other cables;

It should have corresponding simple signal at both sides of the cable for maintaining.

【Specifications】

Technology:

Standard: IEEE802.3, IEEE802.3u, IEEE802.3x, IEEE802.3z

MAC address table: 1K

Interfaces:

Gigabit SFP port: 1000Base-X, LC

Ethernet port: 10Base-T/ 100Base-TX, RJ45 port, full/half duplex mode, MDI/MDI-X

Led indicators: PWR, Link/ACT

Transfer distance:

Twisted-cable: 100M (CAT5/CAT5e)

Multi-mode: 1310nm, 5Km

Single mode: 1310nm, 20Km

1310nm, 40Km

1310nm, 60Km

1550nm, 80Km

Power supply:

Power input: 24VDC (12~48VDC)

Terminal block: 4 bit 7.62mm separation distance

Environmental:

Working temperature: -40°C~75°C

Storage temperature: -40°C~85°C

Relative humidity: 5%~95% (no condensing)

Mechanical:

Shell: IP30, high strength iron shell.

Installation: DIN Rail

Dimension (W×H×D): 136mm×105mm×53mm

Standards:

EMI: FCC Part 15, CISPR (EN55022) class A

EMS: EN61000-4-2 (ESD), Level 4

EN61000-4-3 (RS), Level 4

EN61000-4-4 (EFT), Level 4

EN61000-4-5 (Surge), Level 4

EN61000-4-6 (CS), Level 3

EN61000-4-8, Level 5

EN61000-4-12

Shock: IEC 60068-2-27

Free fall: IEC 60068-2-32

Vibration: IEC 60068-2-6

Warranty

Warranty time: 5 years

Certificates:

CE, FCC, RoHS, UL508 (Pending)