

240Watts Single Output Industrial DIN Rail Power Supply

IT-DIN-240 Series



FEATURES

- Universal AC input range(85~264Vac)
- Support 1+1 or N+1 redundant system (suggest to use redundancy modules.)
- Built-in active PFC,PF>0.95
- High efficiency up to 94%
- Built-in current sharing function
- Built-in current limiting circuit
- Output protections: OVP/OLP/SCP/OTP
- Wide operating ambient temp (-25°C~70°C)
- 150%(360W) peak load capacity
- Easy Fuse Tripping due to High Overload Current
- Excellent Partial Load Efficiency
- Built-in DC OK relay contact
- Can be installed on TS-35/7.5 or TS-35/15
- 100% full load burn-in test
- Suitable for critical applications
- Ultra-slim,45mm width
- 3 years warranty



SPECIFICATION

MODEL		IT-DIN-240-24	IT-DIN-240-48	
OUTPUT	DC Output	24V	48V	
	Rated Current	10A	5A	
	Current Range <small>Note 1</small>	0~10A	0~5A	
	Ripple and Noise <small>Note 2</small>	0~70°C	≤240mV	≤480mV
		-25°C	≤480mV	≤480mV
	Voltage ADJ. Range	24~28V	48~56V	
	Voltage Accuracy	±3.0%		
	Line Regulation	±0.5%		
	Load Regulation	±1.0%		
	Set-up Time	<3S@230Vac		
	Hold up Time	≥20mS(230Vac input, Full load)		
	Temperature Coefficient	±0.03%/°C		
Overshoot and Undershoot	<5.0%			
INPUT	Voltage Range	85Vac~264Vac, 127Vdc-375Vdc		
	Frequency Range	47Hz~63Hz		
	Power Factor (typical)	0.99/110Vac	0.95/230Vac	
	Efficiency (Typical)	94%	93%	
	AC Current (max.)	<3.0 A/100Vac	<1.5A/230Vac	
	Inrush Current (Typical)	<20A/110Vac	<40A/230Vac Cold start	
	Leakage Current	Input—output:<0.25mA Input—PG:<3.5mA		
PROTECTION	Over Load	110%~150% of rated current, Constant current limiting for some time(150% of rated current, last 3S) then PS stop working for 7S,after 7S,if the load ≤rated current, PS will work normally, auto recovery		
	Over voltage	29~33V, constant voltage, Auto recovery	58~63V, constant voltage, Auto recovery	
	Over temperature	105±5°C, detect on heat sink of power transistor; shut down O/P, auto recovery after temperature goes down.		
	Short Circuit	Long-term mode, auto recovery		
ENVIRONMENT	Operating amb. Temp. & Hum.	-25°C~70°C; 20%~90%RH No condensing		
	Storage Temp. & Hum.	-40°C~85°C; 5%~95%RH No condensing		
SAFETY & EMC <small>Note 3</small>	Safety Standards	meet UL508, UL60950, EN60950		
	Withstand Voltage	Primary-Secondary: 3.0KVac; ≤10mA .Primary-PG: 2.5KVac; ≤10mA. Secondary-PG: 0.5KVac≤20mA.		
	Isolation Resistance	≥100M ohms		
	EMC Emission	Compliance to EN55022, EN55024, FCC PART 15 Class B		
	Harmonic Current	Compliance to EN61000-3-2, CLASS A		
	EMC Immunity	Compliance to EN61000-4-2,3,4,5,6,8,11; heavy industry level		
OTHERS	MTBF (MIL-HDBK-217F)	More than 300,000Hrs (25°C, Full load)		
	Dimension (L*W*H)	45*124*119mm		
	Packing	24pcs/CTN, 21Kgs/CTN, 0.045cbm		
	Cooling method	Cooling by free air convection		
Additional function	Power boost	150% of rated current		
	Parallel function	support		
	DC-OK	V On: when output voltage is up to 90% of rated output voltage		

		V Off: when output voltage is down to 80% of rated output voltage
	DC-OK relay contact rating	Max 30V/1A or 60V/0.3A or 30Vac/0.3A Resistive load
NOTE	1. All parameters NOT specially mentioned are measured at rated input, rated load and 25°C of ambient temperature. 2. Measured at 20MHz of bandwidth by using a 12" twisted pair-wire terminated with a 0.1 uF & 10uF parallel capacitor.	

Mechanical Specification

Unit: mm

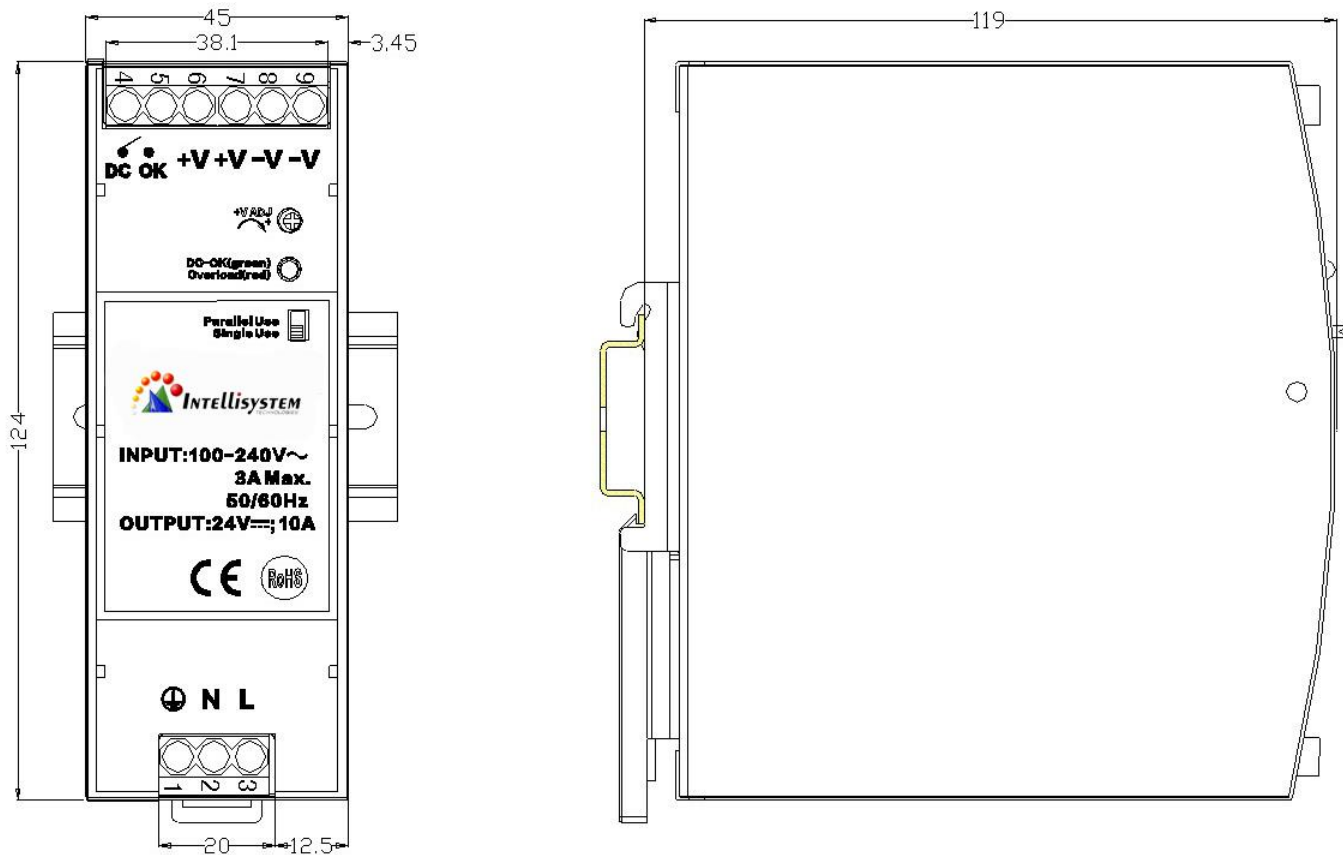

1.AC Screw terminal information

No.	Function	Wire Specs	Recommended torque
1	PG	20~10AWG	5Nm
2	N		
3	L		

2.DC terminal blocks installation information

Terminal No.	Function	Wire Spec	Recommended torque
4 & 5	DC OK Relay Contact	20~10AWG	5Nm
6 & 7	+V		
8 & 9	-V		

	AC/DC Terminal
Type	Screw terminal blocks
Solid Wire	0.5-6mm ²
Strand Wire	0.5-4mm ²
Wire Spec	AWG20-10 (PG wire >18AWG)
Max Wire Diameter	2.8mm
Recommended stripping length	7mm
Screwdriver	3.5mm Straight or Cross Screwdriver
Recommended Torque	5NM

■ Block Diagram

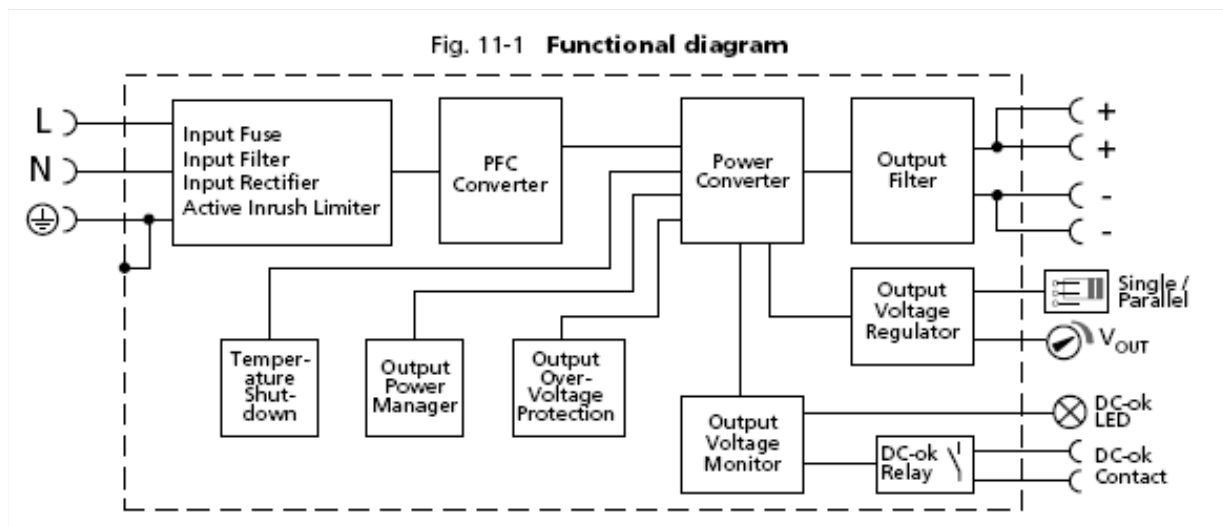

■ Derating Curve

IT-DIN-240-24:

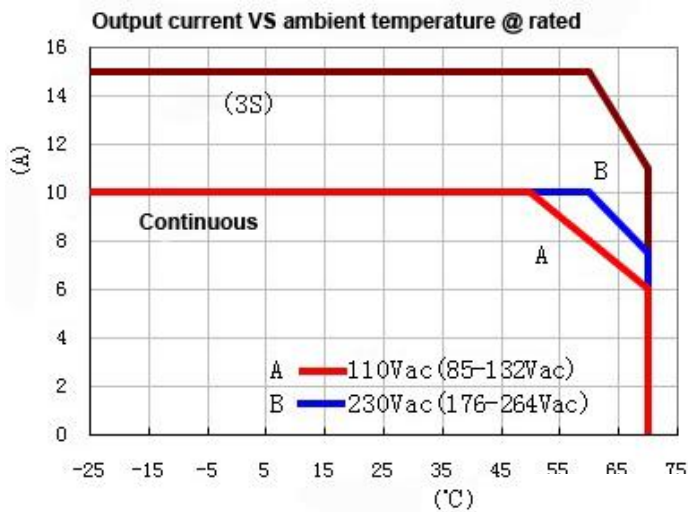

- short time working,3S
- continuous working

IT-DIN-240-48:

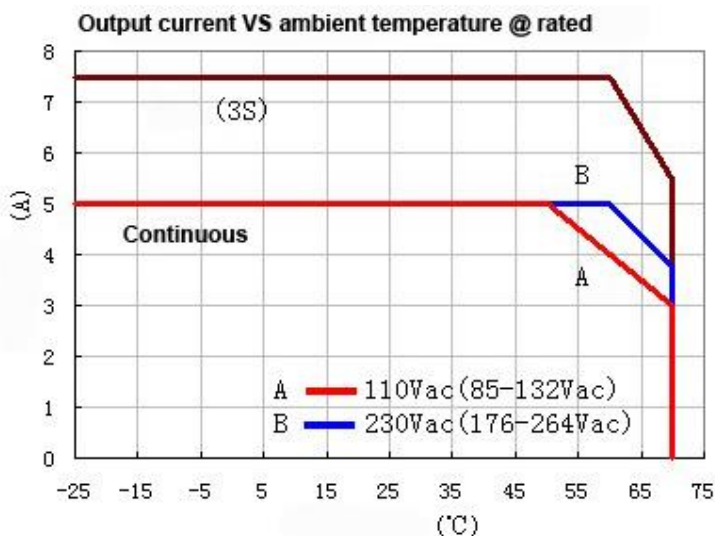

- short time working,3S
- continuous working

■ Mounting method instruction

A1 is recommended output current

A2 is the allowed max output current (PSU lifetime is around half of A1)

IT-DIN-240-24:

Mounting A:

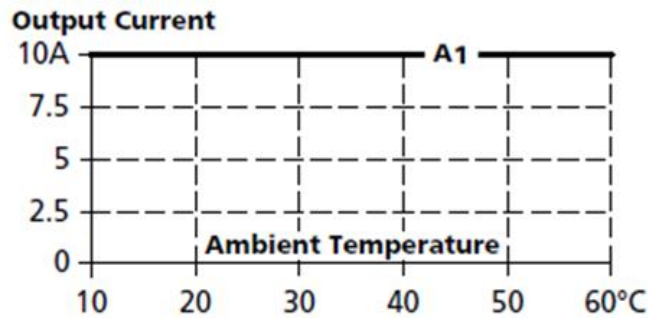
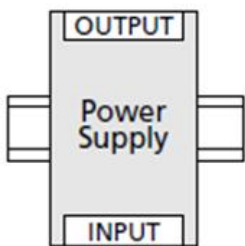

Mounting B:

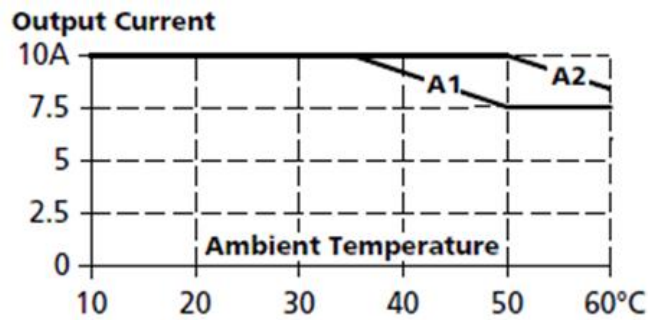
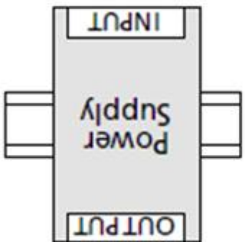

Mounting C:

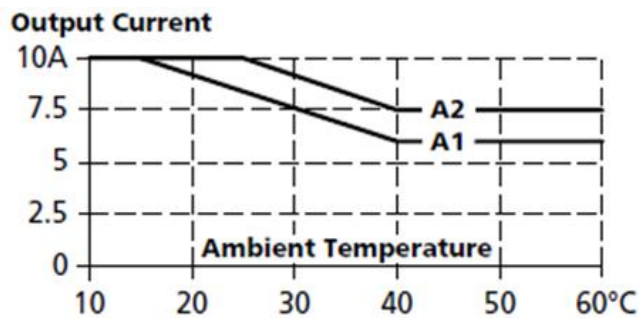
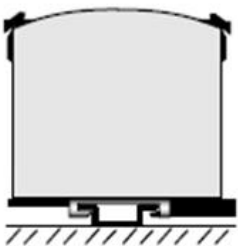

Mounting D:

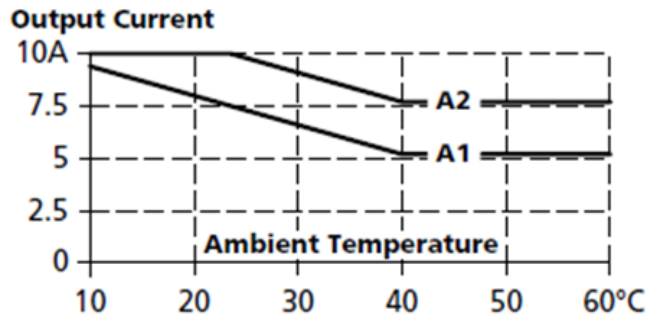
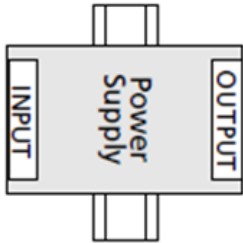

Mounting E:

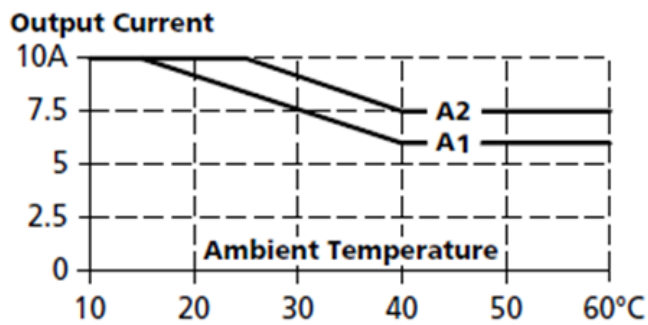
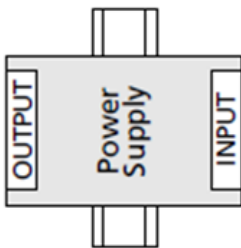

IT-DIN-240-48:

Mounting A:

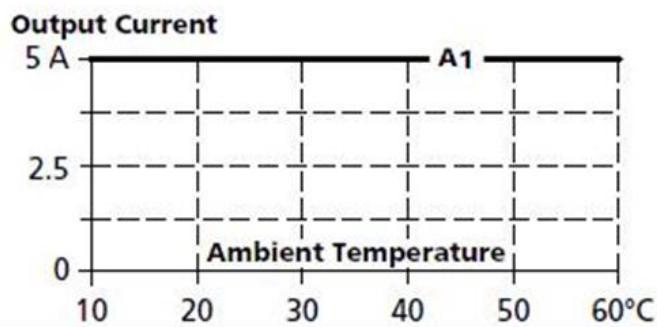
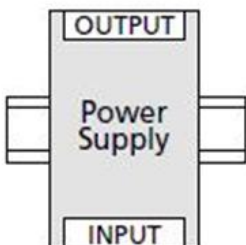

Mounting B

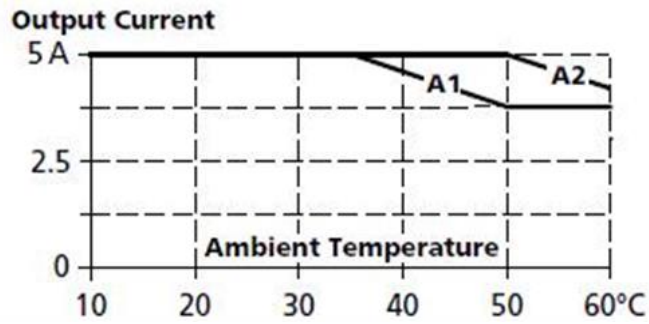
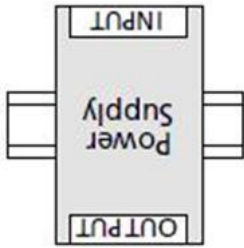

Mounting C

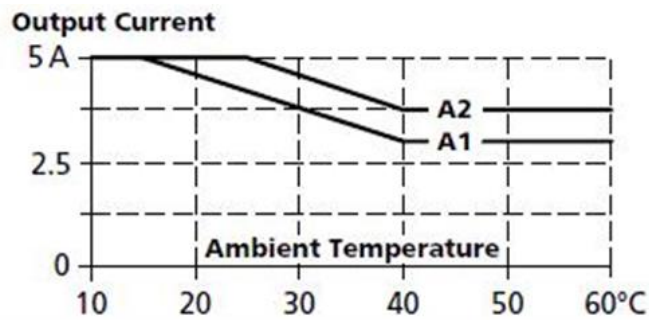
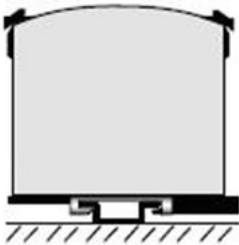

Mounting D

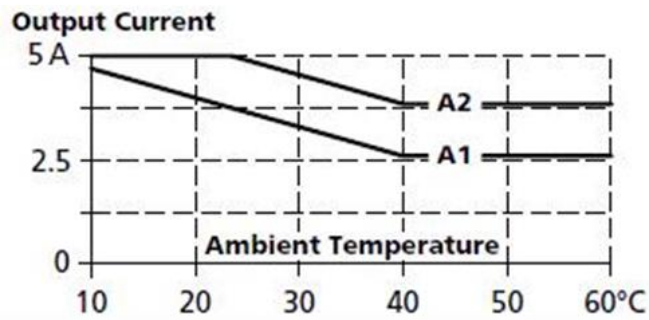
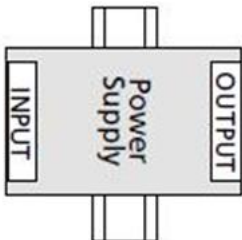

Mounting E

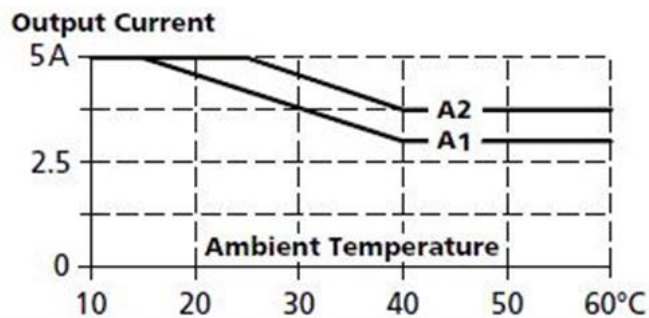
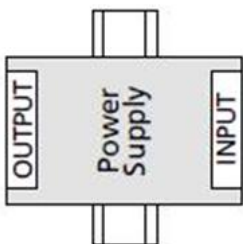

Disclaimer

All products, product specifications and data are subject to change without notice.