

IT-SSG12-IR

With 12 high power LEDs for a total power consumption of 28W, beam angle 15° to 120°, beam distance 150m to 30m, the IT-SSG12-IR is an IR Illuminator with a high service of life.

- Wavelength 740nm/850nm/940nm.
- 50.000 hours lifetime LEDs.
- Extended working temperature range -30 to 50°C.
- 1-3 years warranty.



IR LAMP

HI-POWER
LEDENERGY
SAVINGAUTO D/N
CONTROL

Product Family

The IT-SSG12-IR is part of the high-power Vandal Resistant IR Illuminators series that is the quality LED light source solution for night-time illumination, providing high-power infrared light for CCTV and IP cameras to enhance night-time visual performance.

Professional Design

- Precise secondary optical technology.
- The latest LED technology assures outstanding performance with excellent luminous efficiency and more uniform illumination.
- Independent innovation of high efficiency power drive schemes.
- Low failure rate of products is guaranteed by the professional in-house optimized independent circuit technology, which has been widely used in the illuminators for more than 5 years.
- Vandal resistant.
- Vandal resistant panel protects against hammer, stone and continuous thumping in a certain range.
- Energy saving technology.
- All illuminators has energy saving circuit with low electrical power consumption.
- Thinner and lighter design.

Basic Functions

- *To improve performance of the weak light camera, thereby enhancing the picture effects at night.*
- *Conventional night monitoring.*
- *The function of video analysis at night.*
- *Reduce signal noise and other image distortion.*
- *Reduce the network bandwidth requirements.*
- *Energy saving by power factor correction.*
- *Reduce the equipment cost.*
- *Lower cost of installing and wiring.*

Technical Specifications

LED type: 12 pieces high power IR LEDs

Wavelength: 740nm/850nm/940nm

Beam angle: 15 to 120°

Beam distance: 150m to 30m (850nm)

Bracket: Wall mount bracket

Working voltage: AC110-220V/DC12V

Power consumption: Max 28W (850nm)

Day& Night switch: Automatic/adjustable

Working temperature: -30 to 50°C

Protection level: IP65 (with adjust) / IP66 (without adjust)

Color: Black

Panel: Vandal proof Polycarbonate panel

Housing: Aluminum die-casting housing

Net weight: 1.4 kg (with AC110-220V PSU)

Gross weight: 1.7 kg (with AC110-220V PSU)

Packing dimensions: 185*155*110mm

Models for Selection

Model	Beam angle	Viewing IR distance
IT-SSG12-15-IR	15°	150m
IT-SSG12-30-IR	30°	100m
IT-SSG12-45-IR	45°	70m
IT-SSG12-60-IR	60°	50m
IT-SSG12-90-IR	90°	40m
IT-SSG12-120-IR	120°	30m

**Viewing IR distance is tested by Sony 1/3 CCD Camera and 850nm IR LEDs.*

To achieve the distance needed, please pay attention to your camera specifications and lens before purchase. It is normal phenomenon that distance may vary due to different cameras and lens.

Adjustment and Installation



Mechanical Drawings

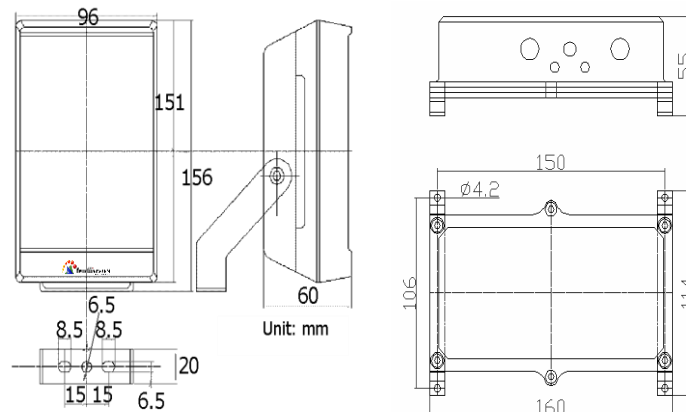

Viewing Picture at Night



With IR



Without IR