

IT-1203SZN-IRFL License Plate Recognition Flash Lamp



Product Overview

IT-1203SZN-IRFL is designed as the high efficacy light sources for application system of license plate recognition. Under the condition of complete darkness, it helps camera system obtaining clearly pictures of number plate, vehicle body and cab.

Features

- High luminous efficiency, long lifespan, good stability, high reliability;
- Anti-glare design, effectively reduce the eye stimulation.

Wiring Definition

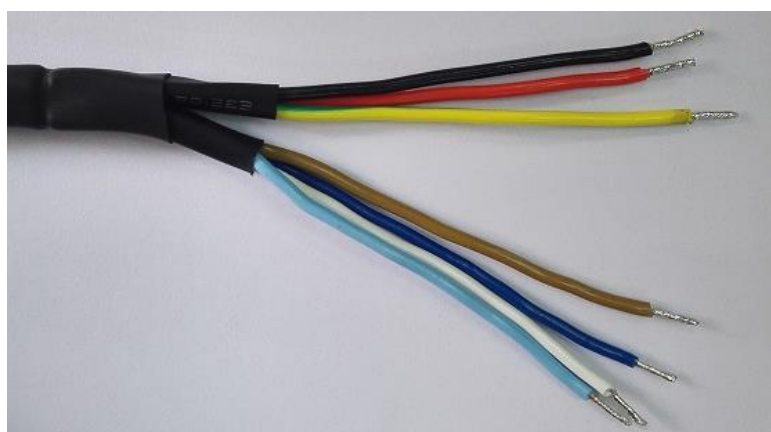

Base pin	Color of outgoing wire	Signal
1	Red	Input AC220V L-line
2	Black	Input AC220V N-line
3	Yellow-Green	Input AC220V PE
4	Brown	Strobe trigger +
5	Blue	Strobe trigger -
6	White	Bright control+ (reserved port)
7	Light Blue	Bright control- (reserved port)

Technical Specifications

Items	IT-1203SZN-IRFL
Flash energy	16J
Wavelength	850nm
Recycle time	< 400ms
Peak flash duration	< 0.1ms
Operate life	≥3million times
Trigger mode	Low electric level, switching value
Cover area	10m~11m@22m
Effective range	4m~22m
Working voltage	154VAC~265VAC
Frequency	48Hz~52Hz
Power consumption	Average power<16W(@1 flash/s), Maximum power In instant<150W
Working temperature	-20~+60°C
Working humidity	5%~95%@40°C, No condensation
Protection level	IP66
Dimension	173mm*173mm*143mm
Net Weight	2.50kg

Dimensions

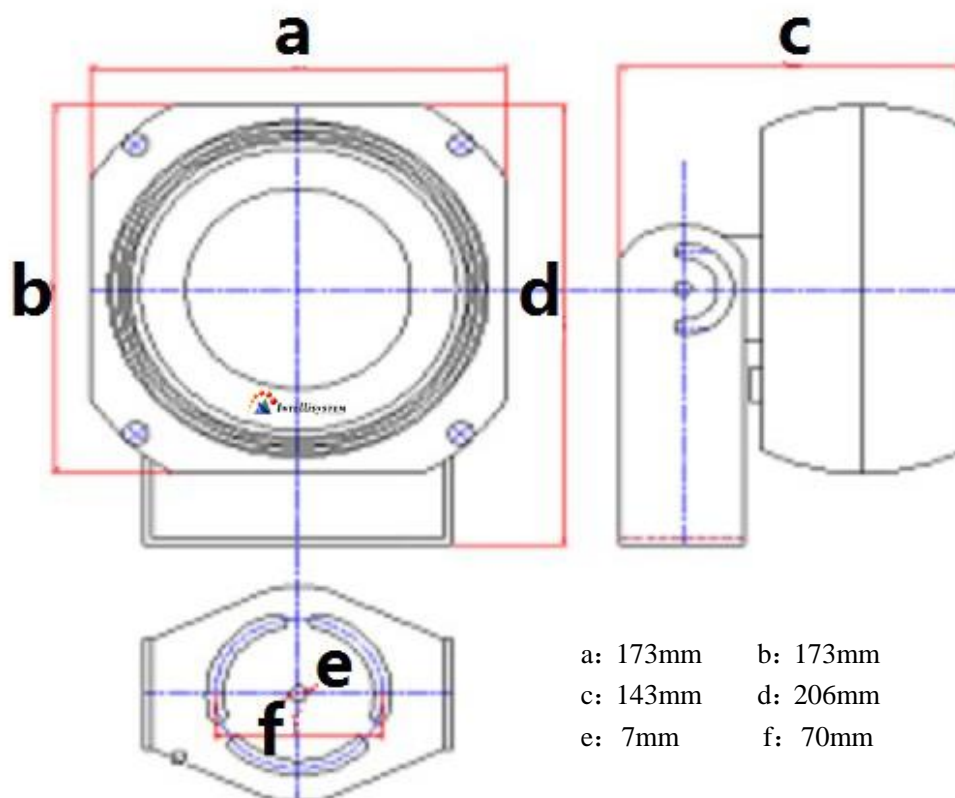

a: 173mm b: 173mm
c: 143mm d: 206mm
e: 7mm f: 70mm

Matters need attention

1. Except artificial reason and the force majeure, the light tube is under 3million times warranty, control circuit has 24months warranty, lifetime maintenance with cost price.
2. Using outdoor electronic product safety reasons, the ground wire must be connected to the qualified ground device to protect the products.
3. The product powered with high voltage. It is strictly prohibited to open personally.
4. The flash lamp has automatically high temperature protection, when internal temperature is over 100°C the lamp will stop working till it reduce to lower temperature.
5. To avoid water in, the power port must be downward and the power wire must not be tighten.
6. We seek to make the accuracy between product and data, but we can't cover all the application field.
7. Specification and design are subjected to change without notice.

Disclaimer

All products, product specifications and data are subject to change without notice.