

IT-3104SZN-WLSL White Light Strobe Lamp

Version: V3



LPR/ANPR PICTURE



Product Overview

IT-3104SZN-WLSL is a high power and smart performance digital pulse strobe lamp applying for Intelligent Traffic System applications. It's suitable for traffic crossing; urban road and high way for number plate recognition and speed measurement. Complied with latest professional strobe control circuit, it can accurately control strobe flash time, brightness and output of high instantaneous power. It has rapid recycling time and long lifespan, through synchronization with the strobe lamp, ITS cameras can obtain clear pictures of number plate, vehicle body and cab under any kind of environment with less influence of human eye.

Copyright Announcement

Trademark, name of software and hardware mentioned in this user manual are all belong to the corresponding company. Without our company's official permission, no organization or individual are allowed to copy or spread this user manual in any form by any means.

The contents of this manual will be changed without prior notice.

Specifications

Model	IT-3104SZN-WLSL-D	IT-3104SZN-WLSL-H
Main Processor	High performance MCU	
LED Type	14 pcs Cree 5W high bright white light LED	
Color Temperature	6000-6500k	
Wavelength	400-780nm	
Center Intensity	150lx@20m	
Beam Angle	10°(standard), 30°, 45° (optional)	
Day/night Switch	Environmental brightness detection, switch on under low illumination	Support camera control
Strobe Interface	Support video and strobe synchronization	
Strobe Mode	Mode D: Compatible with Dahua's ITS camera. Continuous strobe light under 100Hz frequency, duty cycle adjustable.	Mode H: Strobe frequency is in accordance with doubling pulse of camera, duty cycle is adjustable and continuous working (Duty cycle of Hikvision camera should be <50%) False pulse protection.
Power Supply	AC165~220V	
Power Consumption	Average≤30W, Peak:150W	
Best Distance	15-20m, width 5-10m	
Synchronization Port	1 Strobe trigger input	
Trigger Method	Low electrical level / switching value	
Housing Material	Aluminum + toughened glass	
Cooling	Heating dissipating housing	
Lightning Protection	Common mode 4KV, Different mode 2KV	
Protection Level	IP67	
Working Temperature	-40~+60°C	
Storage Temperature	-40~+85°C	
N.W	2.4kg	
Size	122*125*134mm	

Dimensions

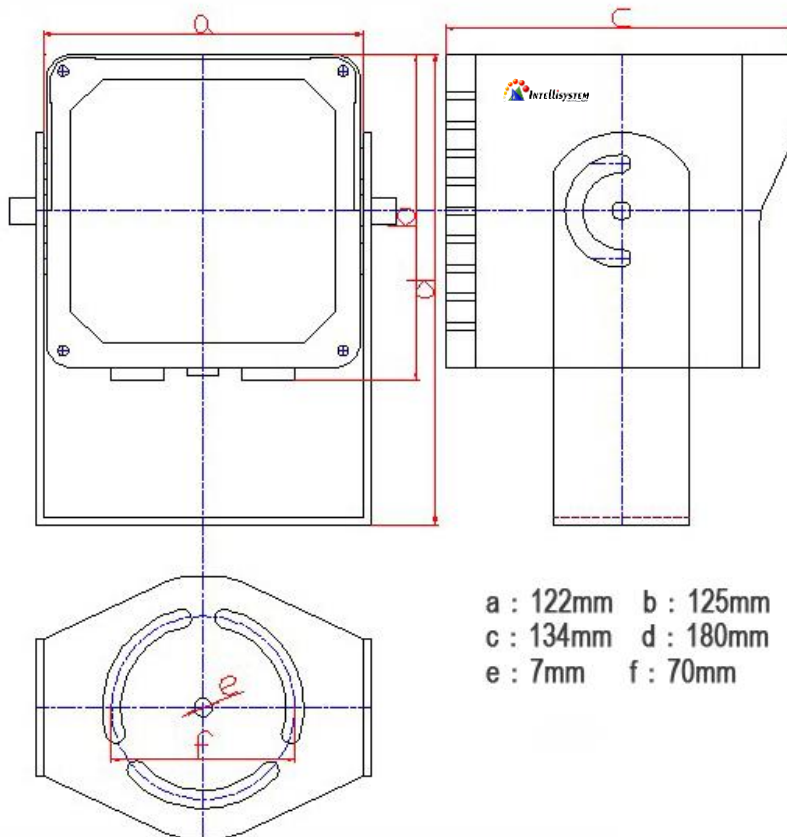

After sales service

Product damaged except artificial reason and the force majeure is under 36 months warranty, lifetime maintenance with cost price.

Disclaimer

All products, product specifications and data are subject to change without notice.

